



sahinler
METAL MAKINE ENDÜSTRİ A.Ş.

K-Q
TSE-ISO-EN
9000

USER'S MANUAL MODEL HPK 100 NC HYDRAULIC SECTION BENDING MACHINE



Balkan Mah. Mümin Gencoğlu Cad. No:14 16285 BURSA / TURKEY

Tel: +90-224-470 01 58 (6 lines pbx) Fax: +90-224-470 07 70

Web: www.sahinlermetal.com Email: support@sahinlermetal.com

EC DECLARATION OF CONFORMITY

MANUFACTURER

NAME : ŞAHİNLER METAL MAKİNA ENDÜSTRİ A.Ş

ADDRESS : Balkan Mah. Mümin Gençoğlu Caddesi No:14 16285 Bursa – TÜRKİYE

TEL : +90 224 470 01 58 **FAKS** : +90 470 07 70 **WEB**: www.sahinlermetal.com

Name and Address of the

Person authorized to compile the

technical file : FERHAN ŞAHİN
Balkan Mah. Mümin Gençoğlu Caddesi No:14 16285
Bursa – TÜRKİYE

The undersigned declares that the described products meet the essential requirements of the below mentioned standards as based on Machinery Directive **2006/42/EU**, Low Voltage Directive **2014/35/EU**, Electromagnetic Compatibility Directive **2014/30/EU**

The item of equipments which identified below has been subject to internal manufacturing checks with monitoring of the final assessment by **ŞAHİNLER METAL MAKİNA ENDÜSTRİ A.Ş**

MACHINE DESCRIPTION : HYDRAULIC PIPE SECTION BENDING MACHINE

MODEL : HPK-100 NC /

APPLICABLE DIRECTIVES :

2006/42/EU MACHINE SAFETY DIRECTIVE

2014/35/EU LOW VOLTAGE DIRECTIVE

2014/30/EU ELECTROMAGNETIC COMPATIBILITY DIRECTIVE

APPLICABLE REGULATIONS :

EN ISO 12100:2010; EN ISO 13849-1:2015; EN ISO 13855:2010; TS EN ISO 13857 :2019;

TS EN ISO 13850; EN 60204-1:2006/A1:2009/AC:2010; EN 61000-6-2:2005;

EN 61000-6-4:2007/A1:2011; EN ISO 11202:2010

SIGNED ON BE HALF OF THE MANUFACTURER

NAME : FERHAN ŞAHİN

POSITION : General Manager

PLACE/ DATE : BURSA /

SIGNATURE :

CONTENTS	Page
<i>Inverse electric protection</i>	1
<i>General Notes</i>	2 - 3
<i>General Warranty Terms</i>	4
<i>General Safety Terms</i>	5
<i>Danger Zones</i>	6
<i>Transporting Lifting and Carrying</i>	7
<i>Operating HPK 100 as horizontal</i>	8
<i>Foundation and main dimensions</i>	9 - 10
<i>HPK 100's Technical Properties</i>	11
<i>Capacity Chart For HPK 100</i>	12
<i>Operating the machine</i>	13
<i>Operating the machine for optional equipments</i>	14
<i>Standard equipments for HPK 100</i>	15
<i>Bending Operations</i>	16 - 17
<i>Clutch System</i>	18
<i>Flat bar bending</i>	19
<i>Pipe Bending</i>	20
<i>Leg-In and Leg-Out Rolling</i>	21
<i>T – U - I Section Rolling</i>	22 - 23
<i>Maintenance and Lubrication</i>	24 - 26
<i>Lubricating the guide rollers</i>	27
<i>Hydraulic Plans and Parts List</i>	28 - 29
<i>Main Part Lists</i>	30 - 35
<i>Electric Schemes</i>	1 - 16

GENERAL NOTES

1. Introduction

Thank you for choosing a Şahinler Sheet / Metal Working Machine. We are proud to have you in our long list of satisfied customers all over the world.

This User's Manual is absolutely for your safety and is essential for the machine to have a long production life. As long as you keep up with our Manual you will be able to run your machine smoothly and safely. Keep in mind that the machine is designed absolutely to perform maximum safety and for efficient working.

In this Manual you can find instructions and information about:

- Correct installations of the machine
- Description of the functional parts of the machine
- Set-up and start-up adjustments
- Correct standard and scheduled maintenance
- Simple safety regulations and accident prevention.

Therefore, as far as the user's safety is concerned, in this handbook the possible risks connected with machine operation are pointed out as follows:



ATTENTION: Showing the risks of accident, if instructions are not followed.



WARNING: Showing the probable damages to the machine or equipment, if the instructions are not strictly followed.



NOTE: It gives useful information.

It is certainly necessary that the operator should read and understand all the ATTENTION, WARNING notes specified in this Manual before starting with operation of the machine and before any lubrication or maintenance intervention.

On all steps of installation, operation and maintenance safety must be your first concern for the protection of yourself, other users and the service of the machine.

In case of any failure please first refer to this Manual, and then if a solution cannot be found contact first of all the distributor where you purchased our product. Do not forget to refer to the

drawings and the numbers for any spare part needed or to define any problem. Make sure you have the serial number and production year of the machine.

Our technical staff will make their best to help you in the most convenient way.

2. Transport

As soon as you receive the machine, check for any visible transport damages. Should there be any visible damages; report it straight away to the transporter company and of course Şahinler Metal Mak. End. A.Ş. or your supplier.

Remove any protective crates around the machine and read the instructions on related chapters of this Manual carefully to set up the machine. If the machine is damaged while transport, **immediately take some photographs for insurance claims.**

Take precautions while loading / unloading or moving the machine to avoid any injuries. Refer also to related chapter of this Manual for the best way of handling the machine.

3. Electrical Information

All necessary connection procedure can be found on this Manual. Do not try to connect the machine before reading these procedures and fully understanding the drawings. For any unclear matters get in touch with Şahinler Metal Mak. End. A.Ş. or any of the Şahinler distributors. Have the machine connected by a qualified electric technician. For, as we made clear in the “general conditions of guarantee”, under no circumstances installing mistakes, one of which is the electrical connection mistake, can be covered in the guarantee agreement. Always turn off power before making any connections or disconnecting the machine.

4. Maintenance

Your machine is designed and produced to work efficiently and smoothly. To achieve this you should also take care while operating the machine. Regard Maintenance sections to have the longest life from your machine. Try and use original spare parts where necessary and most importantly do not overload the machine or do not make any unauthorized modifications.

5. Safety

Take all precautions possible to avoid any personal injury while using the machine. Keep in mind to protect the third party people around the machine. Refer to safety instructions.

GENERAL WARRANTY TERMS

- *Your machine is covered by manufacturer's guarantee for a period of 12 months from the date of purchase against manufacture defects. The warranty period does not exceed 18 months from the date of delivery from the manufacturer's factory.*
- *Warranty covers only manufacture defective parts and / or components that are reported as "defective" by a Sahinler Technician or the Agent Technician and must be reported to Sahinler in writing by fax or email.*
- *The manufacturer is responsible for the supply of free of charge spares only and cannot be held responsible for loss of work.*
- *Shipping and customs fees for the spare part must be paid by the end-user.*
- *If a technician travel is necessary Sahinler will not charge for labor and workmanship costs but the customer must pay traveling and accommodation charges.*
- *A Warranty claim does not relieve the Customer from payment obligations.*
- *The Customer can not ask or demand any reimbursement of damage nor the Customer will have the right to extend or delay payment obligations nor the cancellation of order and the refunding of damages as the guarantee is given for the defective parts of the machine and not for the job.*



Note: All warranty claims must be applied with the Model, Serial Number and the Manufacture Year of the machine.

GENERAL SAFETY TERMS

1. Machine's Safety Accessories and Accident Prevention Terms

- *The machine is provided with fixed shelters for the protection of all gears. But some mobile parts, because of their shape for the bending processing cannot be protected within a case. However, safety is guaranteed by the machine features and by the use of "human presence" controls.*
- *The machine is controlled by means of the Mobile Control Panel. During operation the specified safety distance must always be observed.*
- *There is a red mushroom emergency button at the upside of the Mobile Control Panel to stop all the machine activity by disabling the electric supply until released. In case of an extraordinary situation, please push this button straight away.*
- *No other persons except for the qualified and well-trained operator should be allowed to use the machine and to be present in the working area of the machine.*
- *Any damaged or defective connections to the different energy supplies must be replaced.*
- *All interventions concerning installation, start-up, change of equipment, use, change to the use and the operation, regular maintenance, inspection and periodical maintenance can be performed only after disabling the machine according to relevant chapter of this handbook.*
- *For any intervention to change the machine's use, please contact to Şahinler Metal Mak. End. A.Ş. previously and ask for their written approval.*

2. Abnormal Conditions

- *Before connecting the machine double-check electrical connections read the instructions carefully. For, almost 65% of the failure reports we receive are based on either wrong electric connection or use in contradiction to the User's Manual.*
- *Avoid the approach of persons to the operator while the machine is running.*
- *Loading and unloading of the material should be done according to the instructions of this handbook.*
- *During the bending process avoid holding material with the hand.*
- *Never wear garments with loose parts, which may be dragged by the machine parts, long loose hair, necklaces, rings etc.*
- *Never use goods except for the allowed ones as operational materials.*
- *Never run the machine without safety devices.*
- *Don't climb on the machine.*
- *If the customer wants to install on the HPK 80 machine a piece of equipment, which has not been supplied by Şahinler Metal Mak. End. A.Ş., the compliance with the safety conditions explained here has to be checked.*
- *The machine cannot be installed and used in corrosive environments.*
- *The machine must always be operated with one qualified operator who has the required knowledge to use this machine properly.*

DANGER ZONES AROUND THE MACHINE

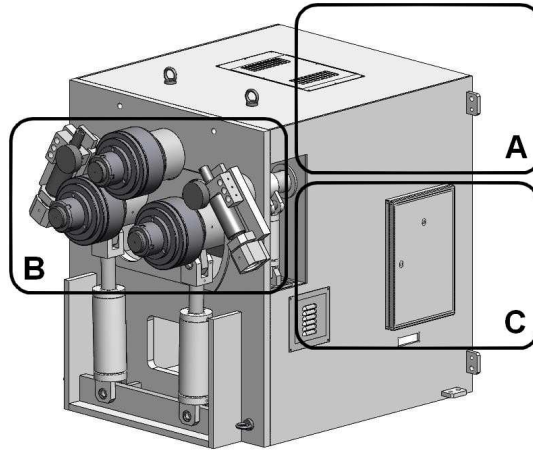

- A - Inside the machine where the hydraulic and power systems are located
- B - The main work area of the machine around the pinch points of rolls
- C - Electric Box on the side of the machine

POSSIBLE INJURY AREAS



Warning :

NEVER PLACE ANY PART OF YOUR BODY TO THESE AREAS WHILE THE MACHINE IS RUNNING

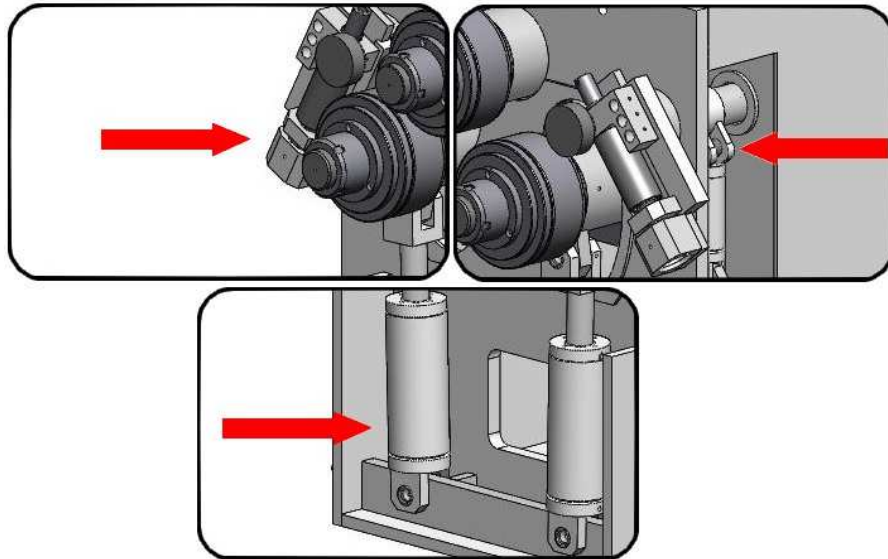

TRANSPORT AND LIFTING OF THE MACHINE

The machine weight is approximately 3630 kgs. Use necessary cranes and lift as shown. Please take extra care during lifting and moving. If necessary consult with specialized companies for lifting.

APPROX MACHINE WEIGHT 4 TONS

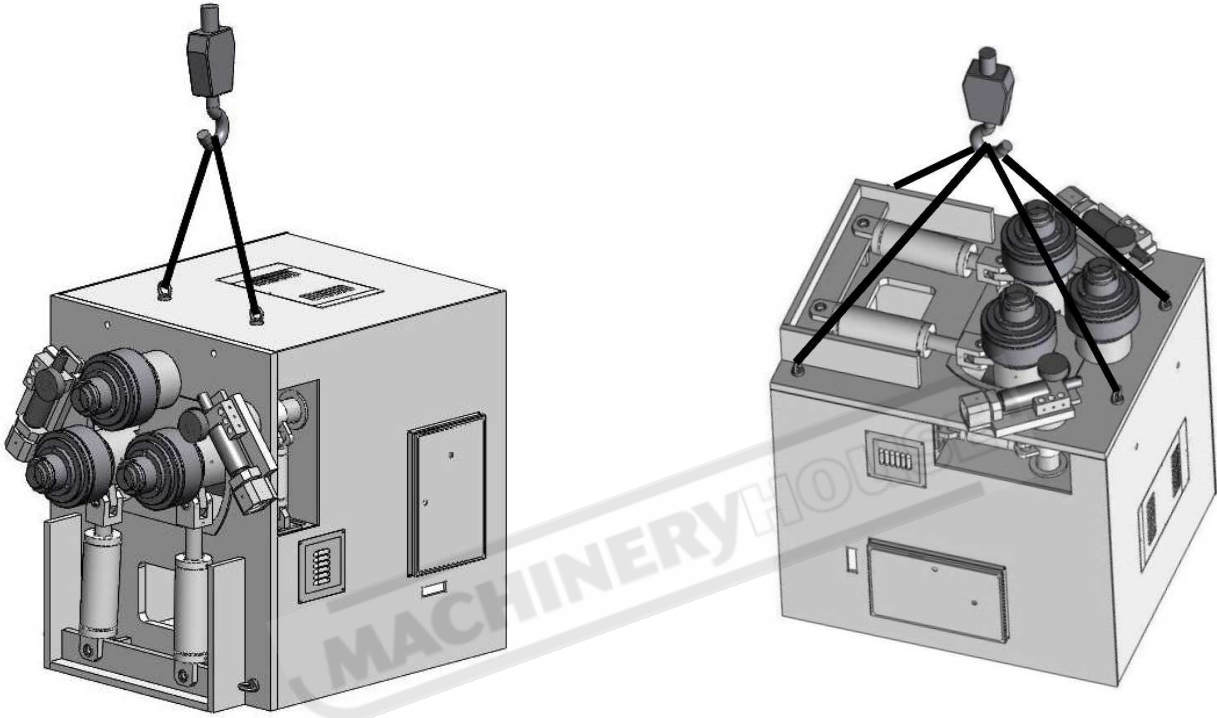

Figure 1

OPENING THE PACKAGE

If any visible damage exist on the machine when you receive the machine immediately informs the dealer or manufacturer. Also never forget to state the visible damage on transport documents.

The packing material is completely safe and do not consist any environmentally dangerous articles. However they must be kept out reach of children as some nylon products in packing may cause suffocation if used as a toy etc.

OPERATING HPK 100 AS HORIZONTAL

Before positioning the machine it is necessary to leave enough working area for the proper bending operations such as extraction of the cylindrical profile, feeding of the semi product, bending of big diameters.

If you have no alternative to install the machine in a broad area but a low-height area, then there is a solution to this problem as shown in figure 2.

To set the machine horizontally follow these steps:

- Wrap a belt capable of carrying at least 4 tons around the top roll's shaft (shown by ① in fig. 1).
- Lift the machine slowly by means of a forklift or a crane with hook.
- After that, slowly lower the machine.

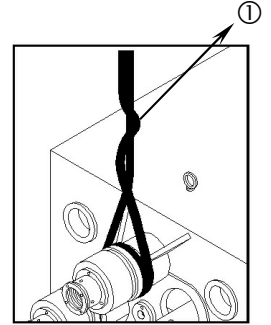

Figure 1



Attention: Do not wrap the belt around the top roll adjustment screw so that it may be bent or its teeth may be damaged.

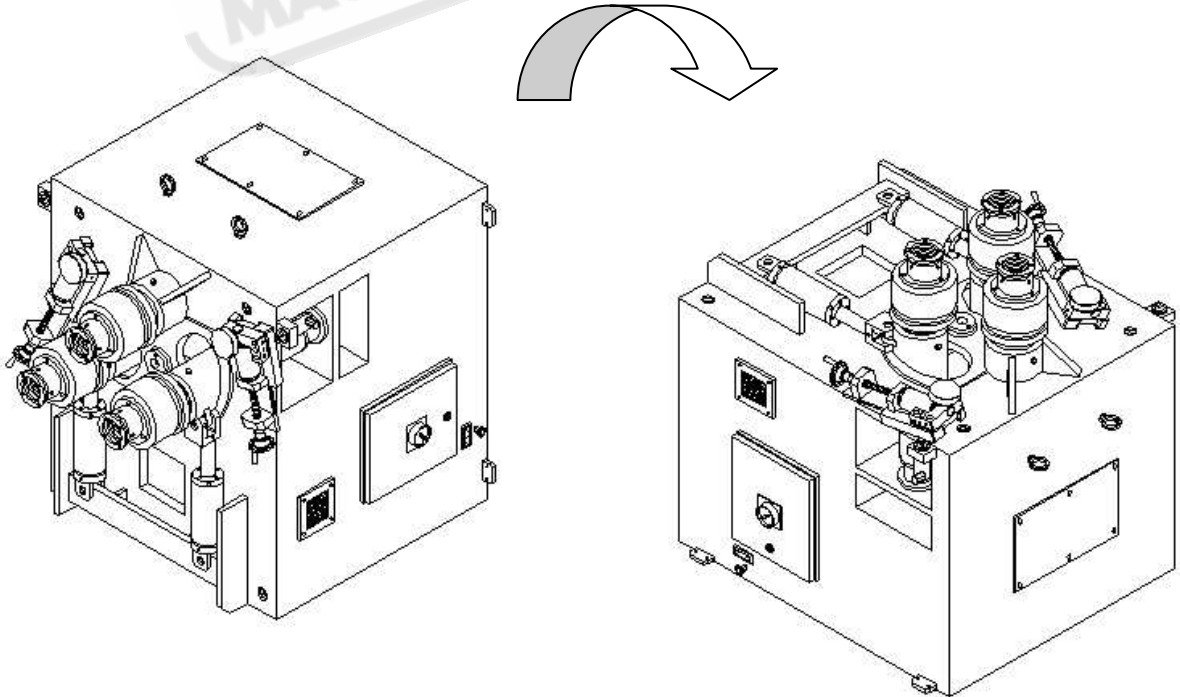

Figure 2

FOUNDATION AND MAIN DIMENSIONS OF THE MACHINE



Note: The manufacturer doesn't accept any responsibility for damages due to the nonobservance of the above specifications.

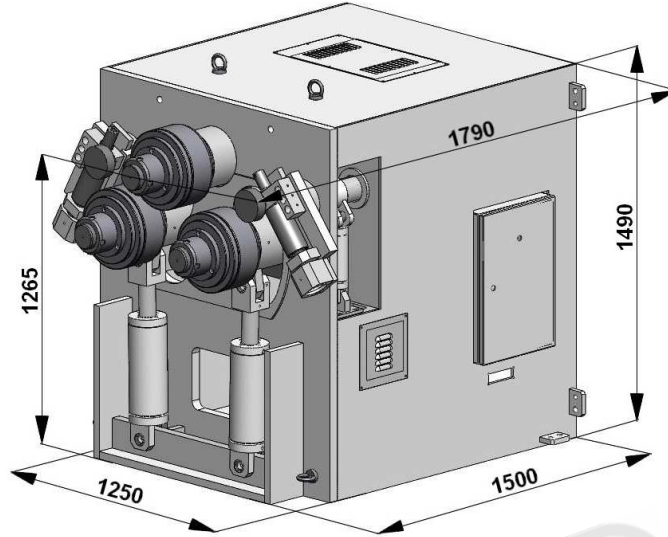

Figure 1

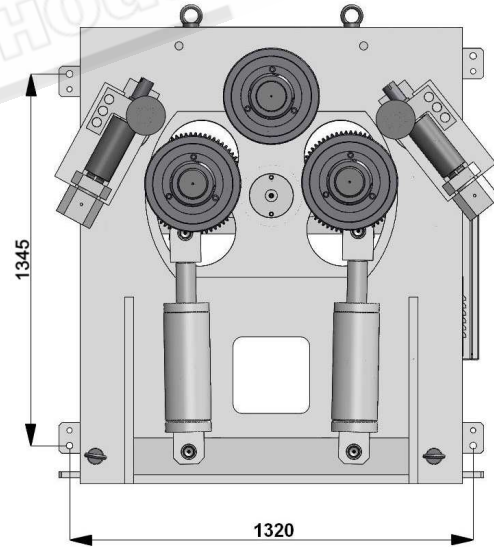
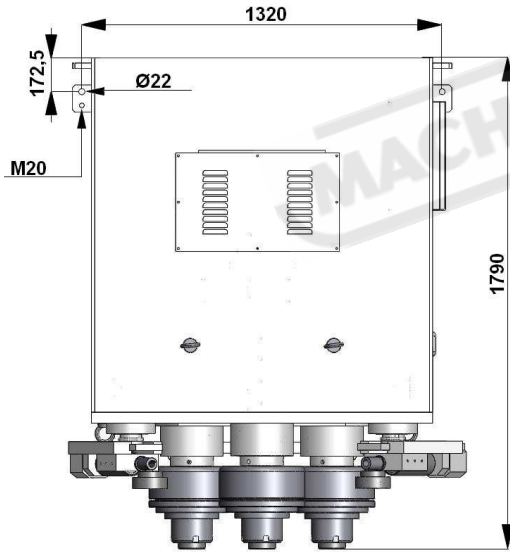
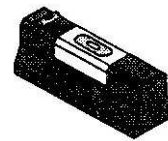

Figure 2

Figure 1,2 shows the main dimensions of the machine. Figure 3 shows the work area. This area is illustrated considering the machine located horizontally. If you operate it vertically, then the borders will be the same. Vertical and horizontal positions are shown figure 4. For vertical or horizontal operations the machine must be placed in a pit as shown and must be bolted to the ground.



Note: All machines must be carefully adjusted before operation with a water gauge.





Note: Always leave necessary safety distance

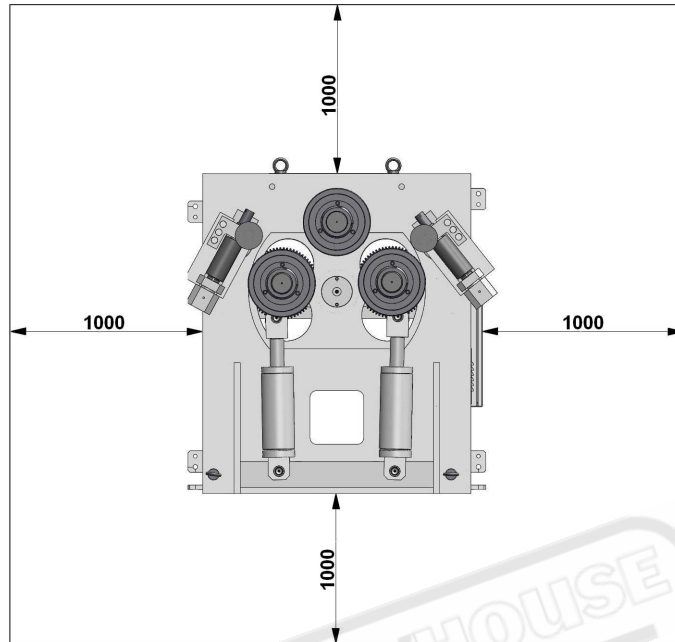

Figure 3

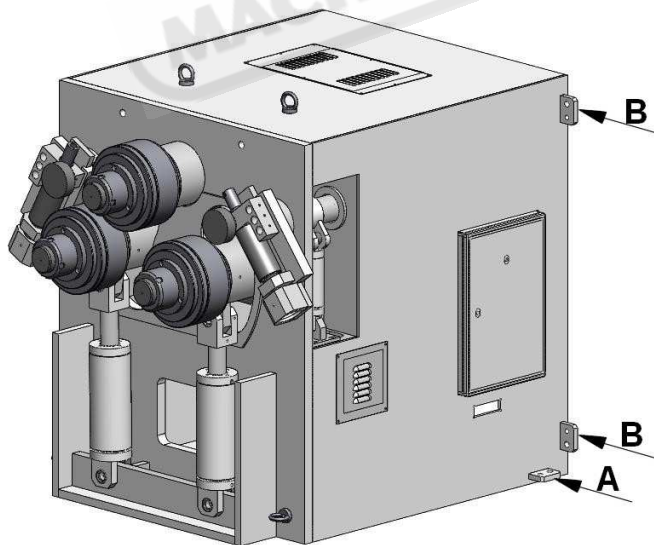
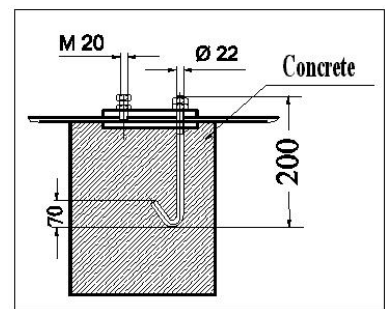

Figure 4



HPK 100's TECHNICAL PROPERTIES

As a superior model in its own class the HPK 100 is equipped with a powerful motor and a low noise reduction gearbox, which gives the machine power to bend with ease. The digital Read-Outs on bottom rolls give higher accuracy and increase the efficiency. By using Mobile Control Panel you can easily and safely bend the required materials. General Technical Information of HPK 100 is given below.



MODEL: HPK 100		
Shaft Diameters	Ømm	100
Roll Diameters	Ømm	315
Working speed	m/min	7
Motor Power	kW	7,5
Weight	kg.	3650
Length	mm	1465
Width	mm	1700
Height	mm	1300

STANDART SPECIFICATIONS

- Three Rolls are Powered
- Steel Construction Frame
- Rolls Shafts are Special Steel Material
- Rolls are Hardened and ground
- Horizontal and Vertical Working Position
- Brake Motor Equipped
- Standard and Hardened Rolls
- Mobile Control Panel
- 3-Axis Mechanical Lateral Angle Guide Rolls
- User's manual
- Digital Read-outs (2 pcs.)

SPECIAL FEATURES

- Pipe, Tube and Profile Bending Rolls
- Hydraulic Lateral Guide Rolls (2 pcs.)

SAFETY UNITS















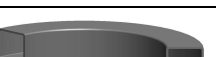

- Emergency Button on Mobile Control Panel
- Various DANGER signs around the machine
- Overload Circuit – Breaker
- Safety lock on main power supply.



Note: Due to various safety regulations, the specifications presented here can change from country to country without prior notice. Above dimensions and other characteristics can also change without prior notice due to our constant improvements on our products.

Please note that some, angle materials and all pipe materials need special rolls. Please ask for special rolls if necessary.

HPK 100 CAPACITY CHART

NO	PROFILE TYPE	SIZE	MIN DIA.	NOTES
1		100x20 30x10	800 400	Standard Rolls
2		200x30 80x5	1200 400	Standard Rolls
3		60x60 15x15	750 400	Standard Rolls
4		Ø75 Ø15	800 450	Optional Rolls
5		Ø125x2,5 Ø15x1	1400 450	Optional Rolls
6		Ø4"x6,02 Ø½"x2,77	1000 450	Optional Rolls
7		100x40x4 25x15x2	1300 450	Optional Rolls
8		80x5 25x2	1500 450	Optional Rolls
9		100x100x12 40x40x4	1000 700	Standard Rolls
10		100x100x10 40x40x4	1000 550	Standard Rolls
11		100x11 30x4	1000 400	Standard Rolls
12		90x10 30x4	1000 400	Standard Rolls
13		100x11 30x4	1000 400	Standard Rolls
14		UPN 180 UPN 30	900 400	Standard Rolls
15		UPN 180 UPN 30	1000 400	Standard Rolls
16		IPN 180 IPN 80	1000 400	Optional Rolls
17		HEB 100 HEA 120	1200 1000	Optional Rolls

- Capacities are given for 24 kg/mm²
- We reserve the right to make changes without



Warning: Do not feed profiles having a higher thickness than specified for the capacity of the machine.

Do not feed more than one piece at a time.

Do not use the machine for any other scope the one for which it has been designed.

OPERATING THE MACHINE

The Mobile Control Panel is your interface with the machine and it is very easy to operate the machine.

Here are the names of the buttons on Control Panel:

1. **Power On Key Switch** - Safety Key Switch. When the machine is not in use please remove the key to avoid unauthorized operation
2. **Rolls rotation button** – Left
3. **Left bottom roll** – Up and down
4. **Power on indicator** – When on this indicates the machine Main Power Switch is on and ready to start
5. **Emergency stop**
6. **Start Button** – To start to hydraulic pump and all functions
7. **Stop Button** - To stop to hydraulic pump and all functions
8. **Rolls rotation button** - Right
9. **Right bottom roll** – Up and Down
10. **Digital displays** - for Roll Left and Right

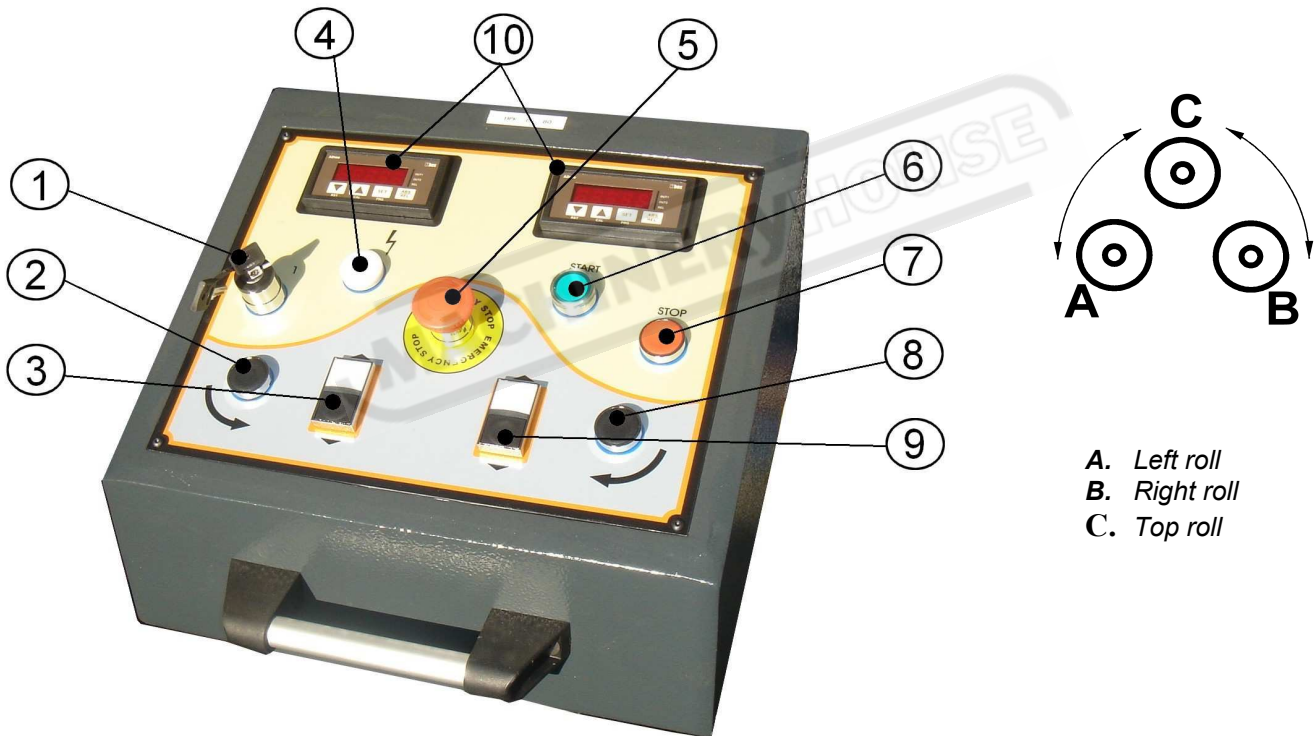

STOP Warning

If the rolls do **NOT** move at this point it means that the electric cables have been connected inverse. immediately stop the machine and reverse the electric cables.

- Try rotating the rolls (No.2 and 7)
- If everything works properly you can proceed with bending

OPERATING THE MACHINE

For Optional Equipments:

- * With Hydraulic Lateral Guide Rolls
- * With Infinitely Variable Speed Adjustment

The Mobile Control Panel is your interface with the machine and it is very easy to operate the machine. Here are the names of the buttons on Control Panel:

1. Guide Roll A Radial Movement
2. Guide Roll A Horizontal Movement
3. Guide Roll A Vertical Movement
4. Rolls Rotate Left
5. Roll A Vertical Movement
6. Power On Indicator
7. Roll B Vertical Movement
8. Rolls Rotate Right
9. Guide Roll B Vertical Movement
10. Guide Roll B Horizontal Movement
11. Guide Roll B Radial Movement
12. Roll A Position Digital Display
13. Roll B Position Digital Display
14. On-Off Key Switch
15. Start Button
16. Stop Button
17. Emergency Stop
18. Speed Control

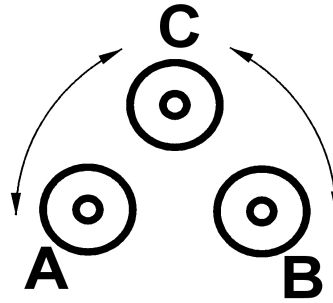

- A. Left roll
- B. Right roll
- C. Top roll

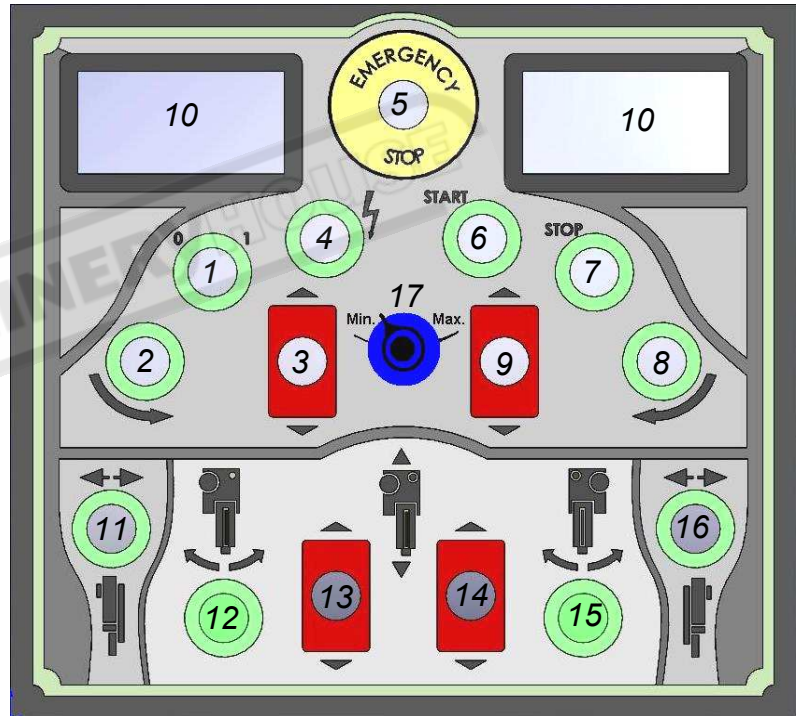

- Turn on the Main Switch on the Machine Electric Panel
- Turn on the Main Power Key Switch(No.14)
- Check that the Emergency Button(17) is released
- Push Start Button(No.15)
- You should hear the hydraulic system activating
- Try moving the bottom rolls up and down(No.5 and 7)



WARNING

If the rolls do not move at this point it means that the electric cables have been connected inverse. immediately stop the machine and reverse the electric cables.

- Try rotating the rolls(No.4 and 8)
- If everything works properly you can proceed with bending
- See Annex for Using the Digitals

OPTIONAL EQUIPMENTS FOR HPK-100

Special guide rollers with hydraulically powered

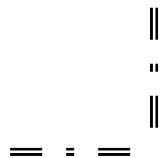
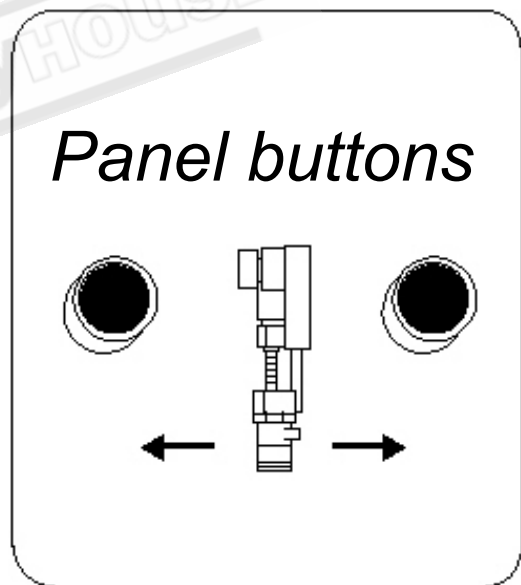
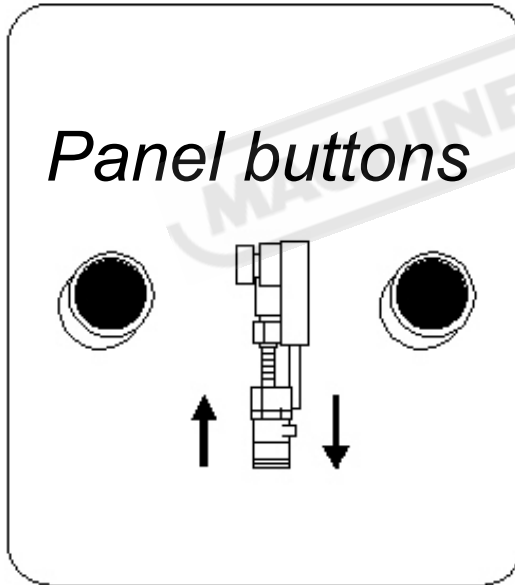
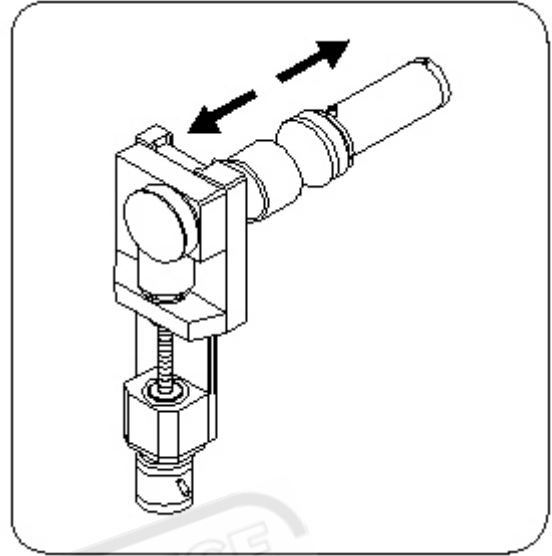
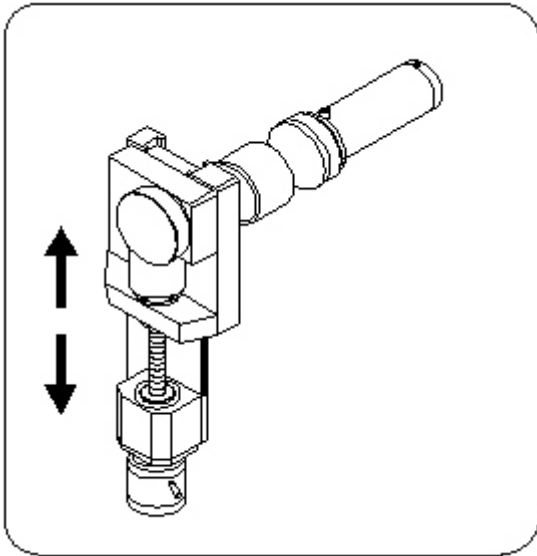

STANDARD EQUIPMENTS FOR HPK-100

Adjusting the mechanic guide rollers

The Guide Rollers are very important on the machine as they directly affect the outcome of any bending to be smooth and accurate.

There are Three axes movements to this system

- Y - Vertical Drive
- X – Horizontal Drive
- Z – Radial Drive

See Mechanic Guide below to understand axes movements

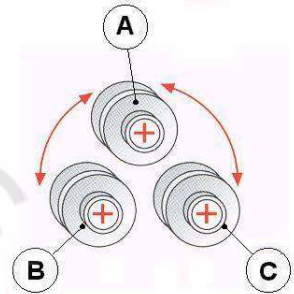

Y – Axis
Up / Down

X – Axis
Forward / Backward

Z – Axis
Radial / Movement



Warning:

Do **NOT** place any part of your body on the Guide Rollers while adjusting them. Be careful to other people around the machine who may be in danger while adjusting.

- A. Top roll
- B. Left roll
- C. Right roll

BENDING OPERATIONS

NORMAL BENDING OPERATIONS

You can feed the material to the machine from both sides. Use the digitalis to adjust the rolls. Also adjust the guide rollers to achieve a better accuracy and better finish.

To give an idea on a simple bending following steps can be taken. Please note that you will get better quality from the machine with experience.

IMPORTANT

If the material to be bent is long we recommend a material support/feed unit for higher accuracy. One feeder/support in each 2 meters should be sufficient.

- Place the material between the three rolls on such a position that the material will be parallel to the ground and touching all three rolls at the same time. This position is called zero position.
- Both bottom rolls must be equally away from the top roll. This rule is applied the same for the machine in Vertical Position (figures 1 and 2).
- Raise one of the rolls depending on the direction of the rolling. And start turning the rolls and when the end of the material reaches between all three rolls raise the other roll and bend in the opposite direction.
- By following the above step you can bend until it reaches the diameter required.
- With the optional equipment of Digital read-outs you can always know the exact position of the rolls



FIGURE 1



FIGURE 2

SPIRAL (HELIX) BENDING

It is rather difficult to make spiral bending and needs experience. The following steps can be taken to start with;

- Arrange the rolls in a position so that they are 3-4 % smaller than the required diameter (Figure 4)
- The guide roller A (figure 5) must be adjusted until the required diameter
- For full diameter bending cut the material as π times the diameter. Remember to leave necessary cut of length. Where at the end of bend two flat parts meet cut of the flat parts and bend until the edges meet.
- In tight spirals where the edge tends to go inside the spiral use a lever to overcome this tendency (Figure 3)
- On arc bending use the guide roll A (figure 5) to obtain the necessary finish arc. If you are bending a pipe the roller A needs to be replaced with a pipe roller also.

During the bend of thin profiles or thin material due to intense bending power a wave may occur on the finished material. Use the nut on Roller B (figure 5) to avoid this problem.

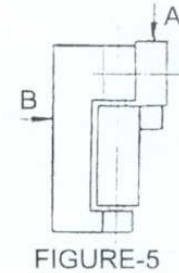
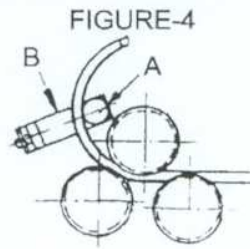
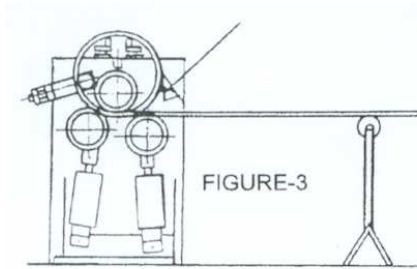

ADJUSTING INSTRUCTIONS

With the HPK 100 machine one set of standard rolls is supplied. If these are arranged and adjusted in combinations most of the profiles and some angle material can be bent.

Adjustment of rolls and correct positioning of the rolls is critical for the efficiency of the machine. Some of the basic references are

- Expansion of the rolls after long term use due to thermal over heat.
- Position of the material between the rolls.
- Position of the spacers.
- Adjusting top roll coupling if necessary
- Positioning using the scale or Digital read-out

When bending too tight material or during serial production you may notice a swelling in the inside diameter of the material. This is due to top roll which expands due to overheat but does not move up. Moving the top roll a little up will solve the problem.

On bending where more power is needed the coupling of the top roll can be loosened to achieve greater rotation or you can use larger top roll so that the material ends are rigidly pushed between the rolls.

Here the rolls and the spacers are numbered below. Use these numbers to position the roll according to the drawings on following pages.

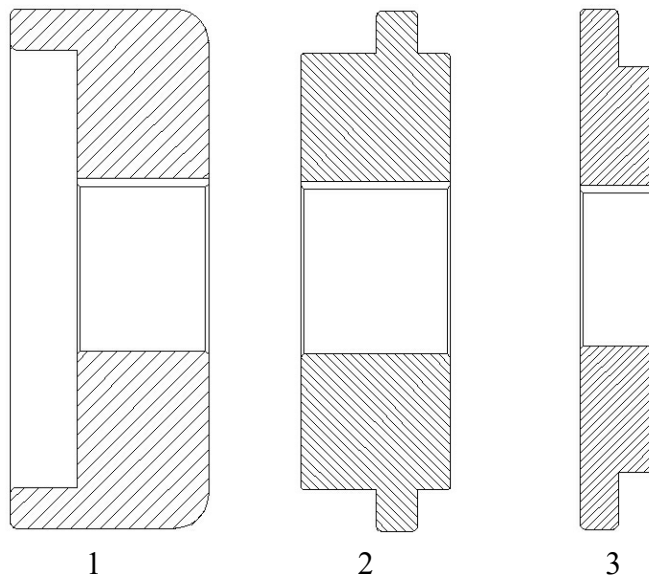

MOUNTING THE STANDARD ROLLS ON THE MACHINE

The rolls must be mounted very carefully according to the figure below. Special combination of these rolls will enable you to bend angles and different bars and some profiles.

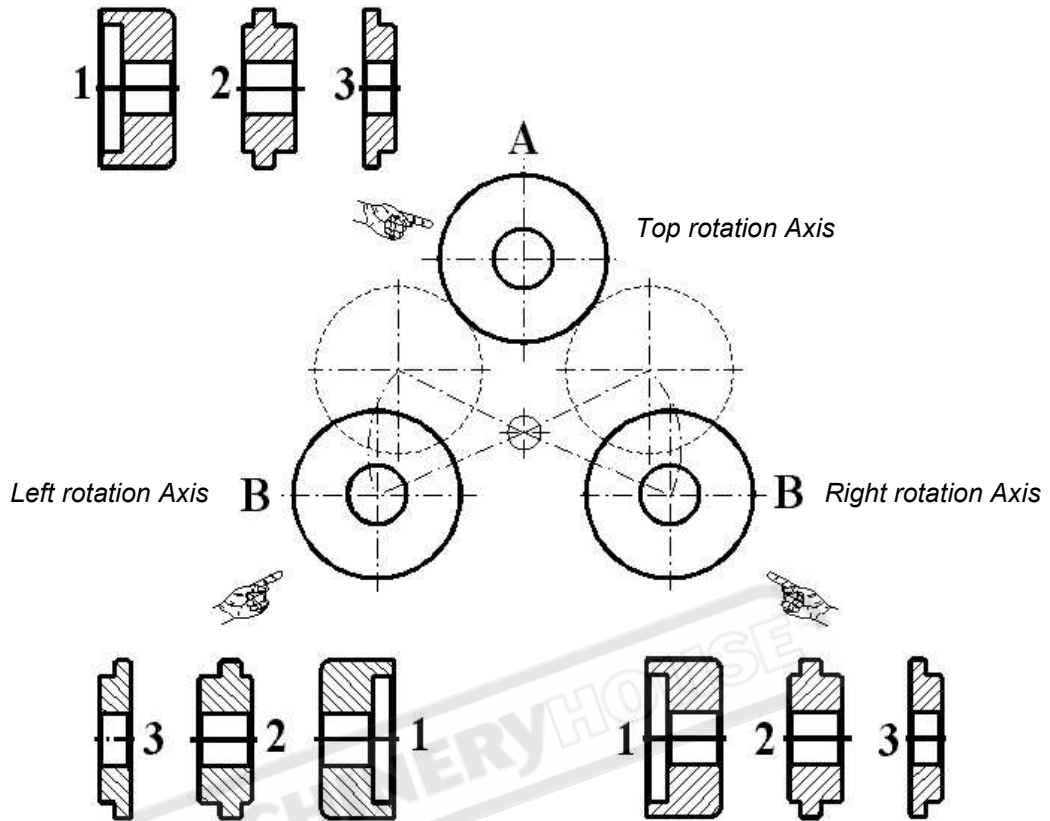

See the mounting figures below and apply them while mounting the rolls for safety. After fitting the rolls to their shafts fit the flange (A) and secure with bolts (C) and flange (B). The flange (B) secures the rolls after being tightened with three socket bolts(D).

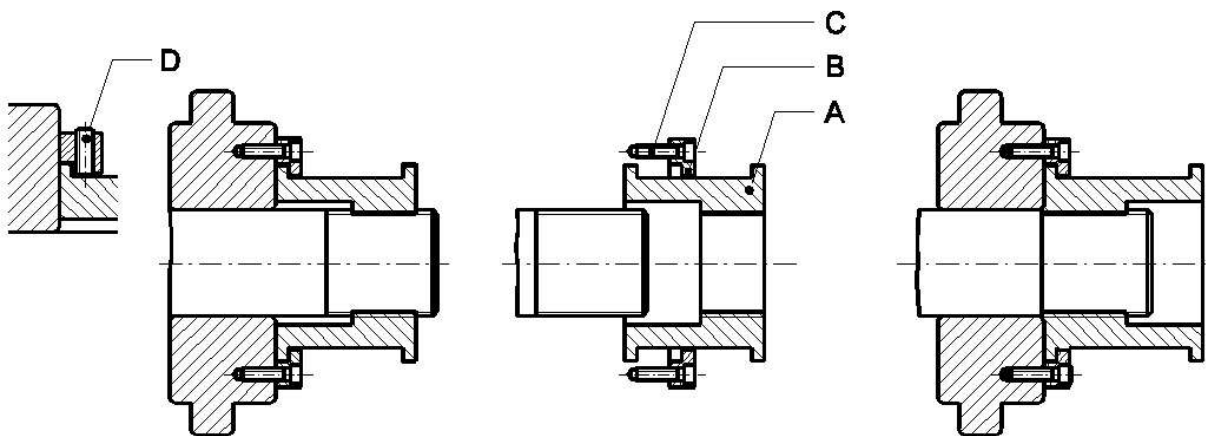

FLAT BAR BENDING

You can bend all kinds of fiat bars the easy way or the hard way by adjusting the rolls as necessary. Some examples are below. See figures 1-2. Also the use of guide rollers (X) is strongly recommended. figure 1 shows how to bend the hard way for high end bars and short and small bars. As always experience will help you achieve better results.

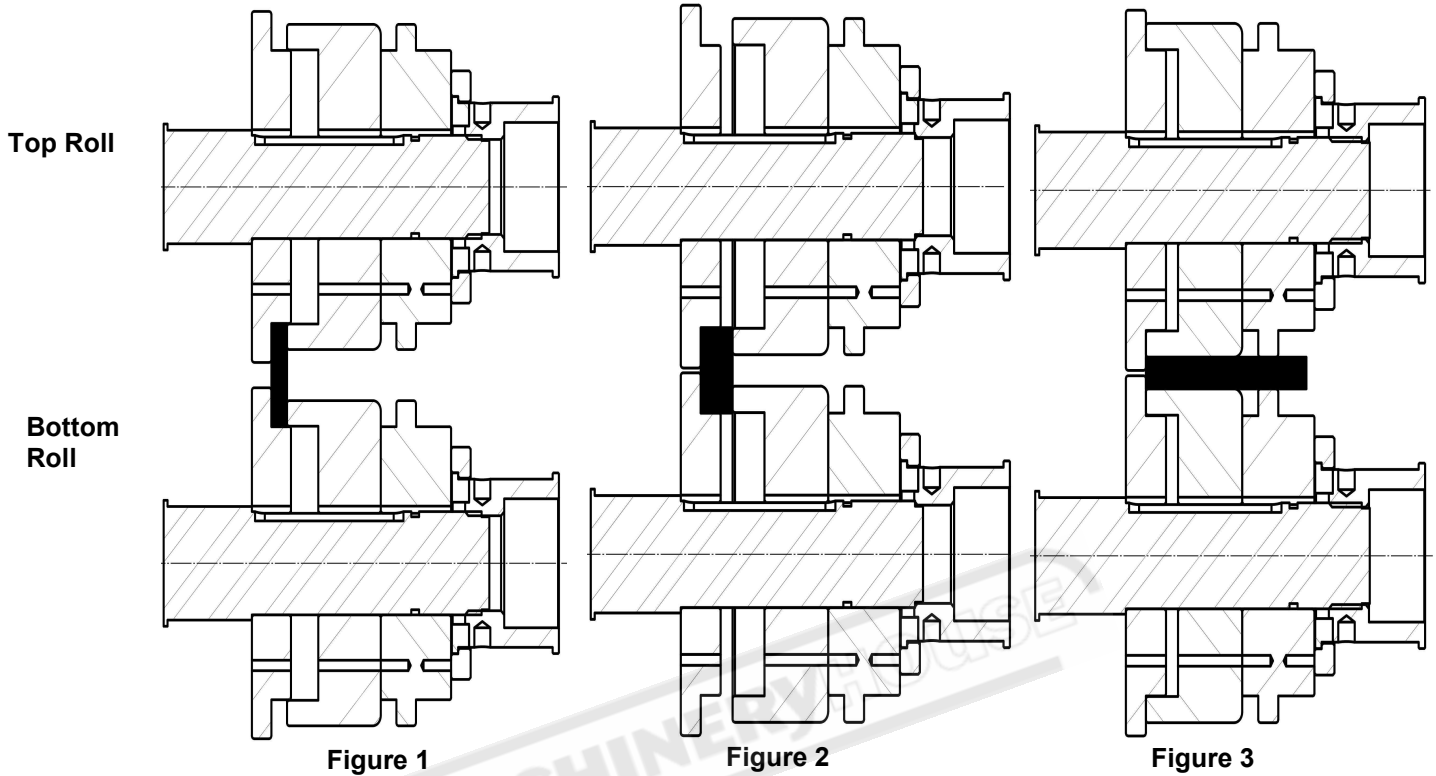

If the profiles are thick walled you can use the rolls as shown in figures 4. If the wall thickness is thin then special rolls must be used.

Bending profiles accurately is somewhat difficult due to tendency of the material to deflect (figure 5) A good recommendation is to fill the profile with a filling material which will resist the bending forces and will help the profile to keep its wall integrity. It must also be noted that this filling material must be easily removable after operation.

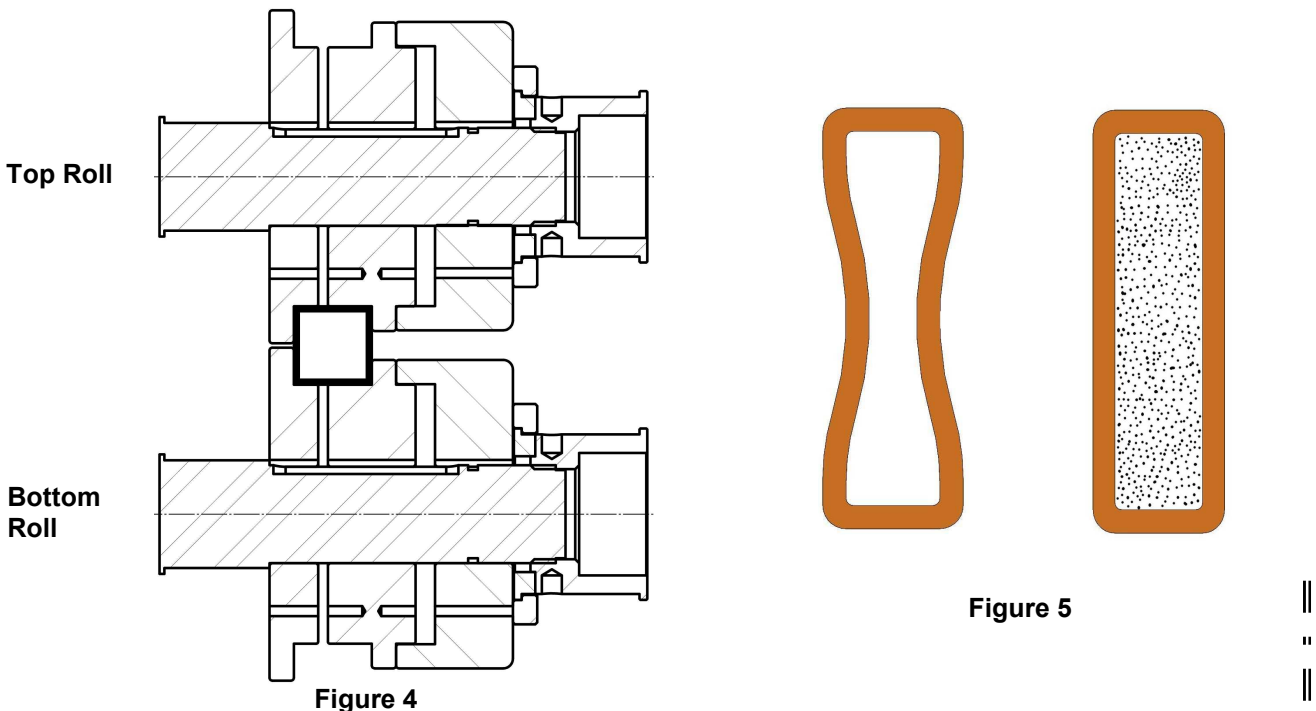

PIPE BENDING

For all different pipes you need a different set of pipe rolls. And the rolls must be precisely adjusted to achieve accurate products. On the specials rolls you buy one of them is numbered "1" and the others are numbered "2". The number "2" rolls must be placed to bottom rolls and number "1" is the top roll. Roll number "1" has a deeper diameter. See figure 1 below

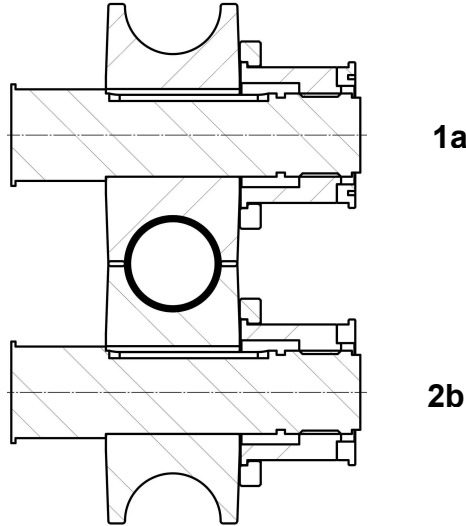

Figure 1
SQUARE BAR BENDING

Figure-2 shows the roll positioning for bending large dimension square bar to large diameters. Figure-3 shows positioning for small dimension squares.

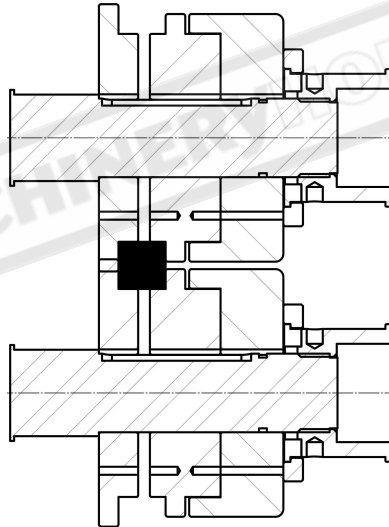
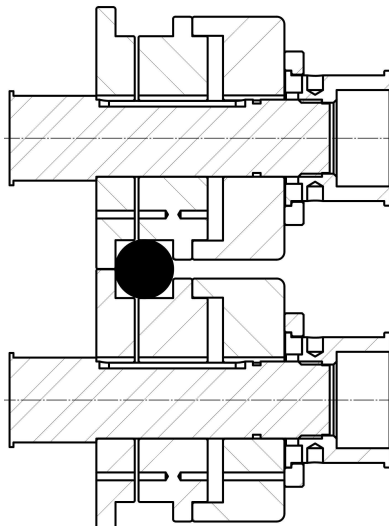

Figure 2-3
ROUND BAR BENDING

Figure-4 shows the roll positioning for bending small diameter round bars. Figure-5 shows the roll positioning for bending large diameter round bars.

Figure 4-5

LEG-IN ROLLING WITH GUIDES

Adjust the rolls for leg-in bending as shown in figure-1. The top roll safety flange must **NOT** be too tight or the material will wave. Both radial (Y) and axial (X) rollers of the guide roller must be touching the material end. (figure-2) adjust the rolls so that a diameter 5% smaller than the necessary diameter can be achieved. This is necessary for the ends of the material to meet at the end of a full circle bending. The radial (Y) must be forcing the material at all steps of bending. (figure-3) the axial rollers (X) must be used to correct the feed direction. If the material is tending to go towards the machine the axial rollers (X) must be pushed more. If the material is tending to bend away from the machine then one of the axial rollers (X) must be pushing too hard. It must be relieved. figure-1 is a set up position for a standard leg-in material. Although you can bend most leg-in materials with standard rolls we recommend you special rolls for serial jobs.

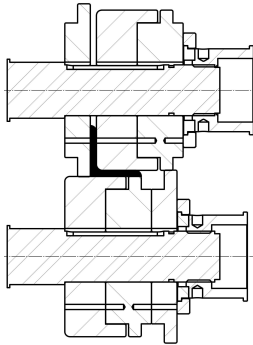

Figure-1

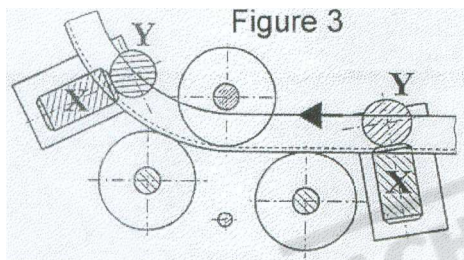
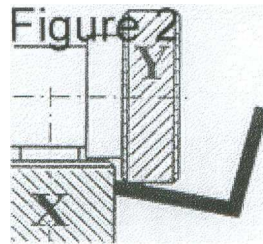

Figure 3

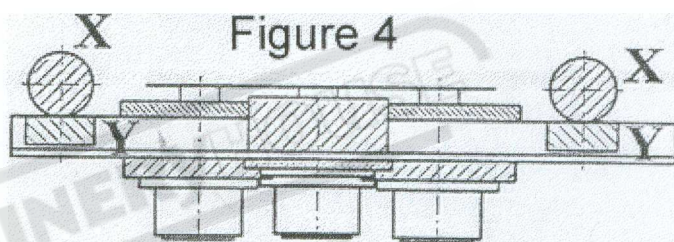

Figure 4

The rolls must be positioned as shown in figure-6 to bend leg-out Distance between the sections (L on figure-6) must be some 10 % wider than the material itself. Adjust the rolls so that a diameter 5% smaller than the necessary diameter can be achieved. This is necessary for the ends of the material to meet at the end of a full circle bending. The radial roller (Y) must be forcing the material at all steps of bending. (figure- 7 and 8)The axial rollers (X) must be used to correct the feed direction. If the material is tending to go towards the machine the axial rollers (X) must be pushed more. If the material is tending to bend away from the machine then one of the axial rollers (X) must be pushing too hard. It must be relieved.(figure-8)

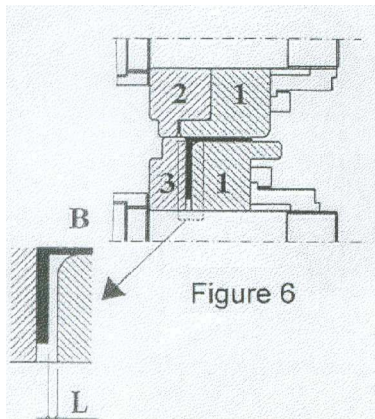

Figure 6

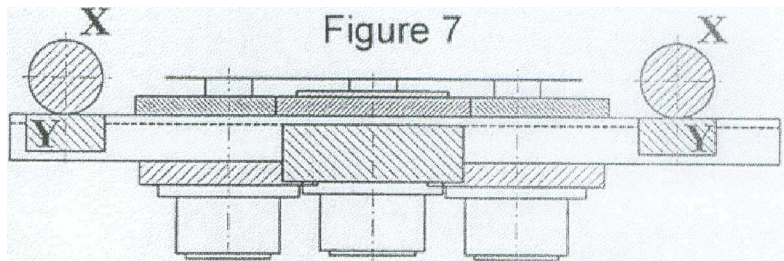

Figure 7

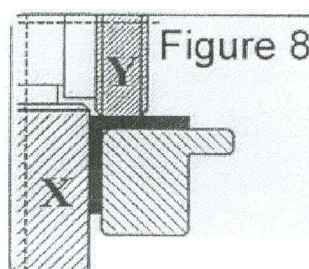

Figure 8

T-SECTION ROLLING

Figure-1 T-Section Inside Bending T-Section Outside Bending

Figure-2 T-Section Inside and Outside Bending with Special Roll
Although you can bend most T materials with standard rolls we recommend you special rolls for serial jobs and better finish and accuracy.

Figure-3 T-Section side bending

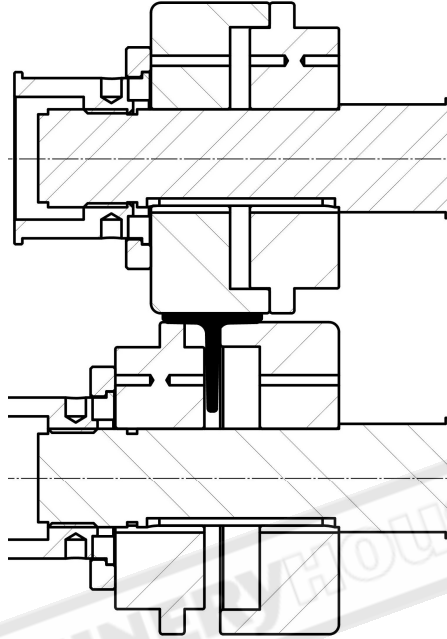

Figure-1

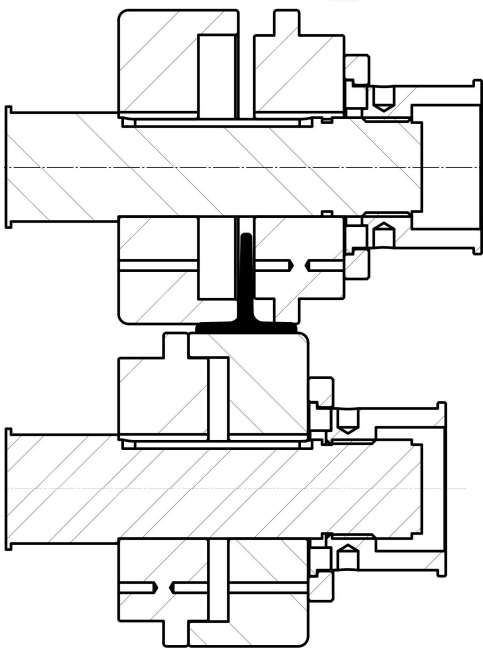

Figure-2

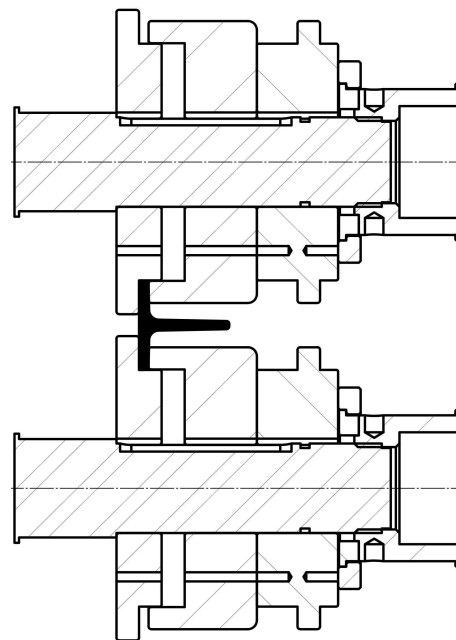

Figure-3



U - SECTION ROLLING

Figure-4 U-Section Inside and Outside Bending

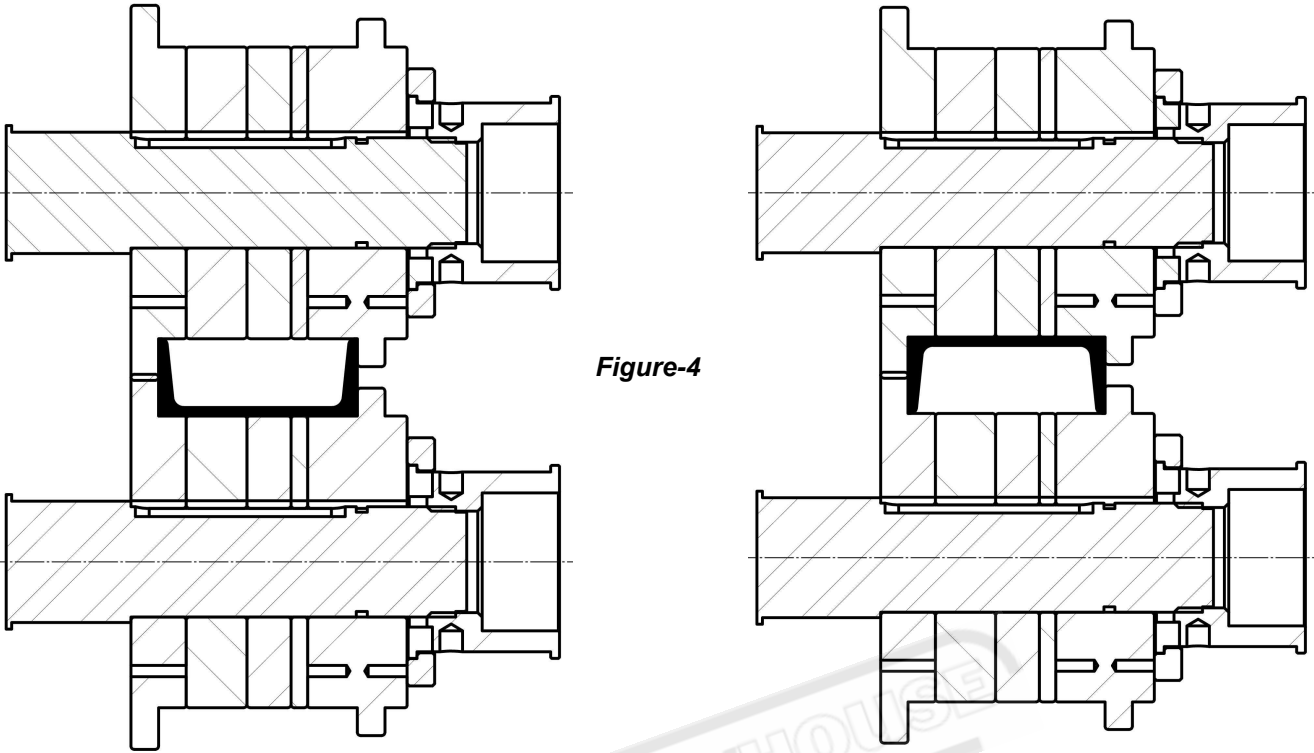

Figure-4

I - SECTION ROLLING

Figure-5 I-HEB Section bending in small or large materials

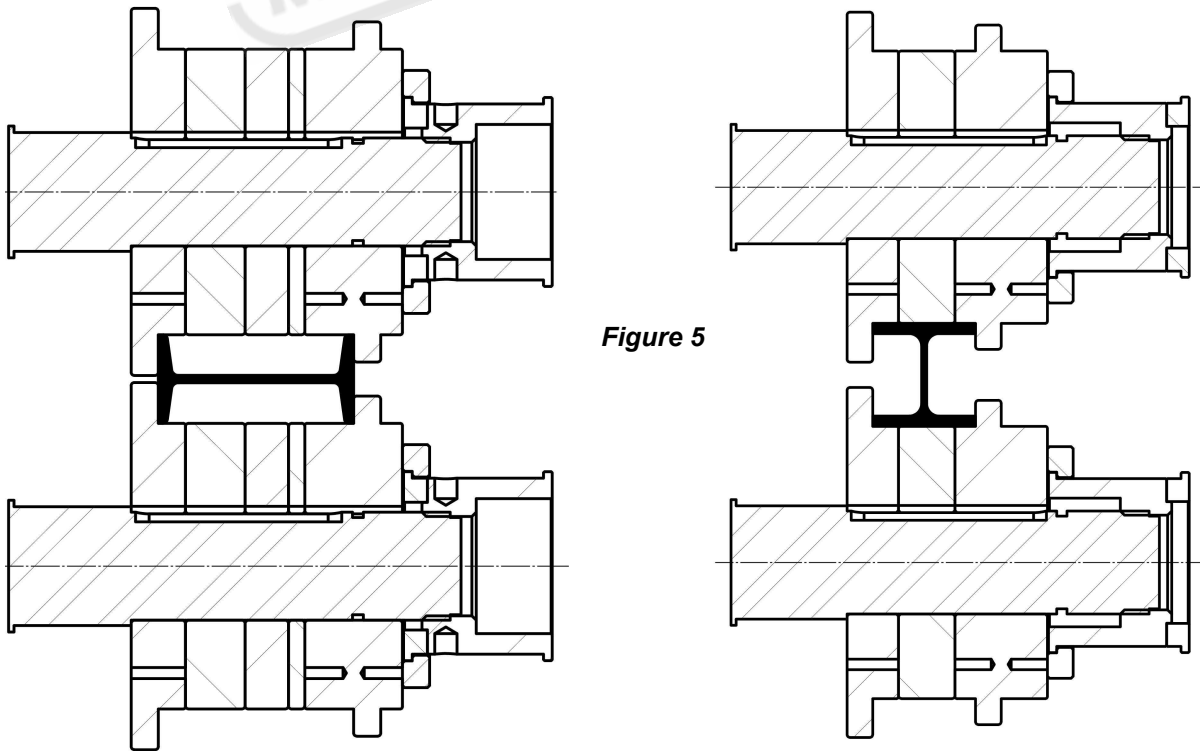

Figure 5



MAINTENANCE AND LUBRICATION INSTRUCTIONS FOR HPK 100

A suitable maintenance is also compulsory to get a maximum machine life and optimal working conditions for machine's efficiency.

A regular maintenance interventions should be performed by a well-trained safety responsible and if possible by a mechanical engineer.



Attention: Regular and scheduled maintenance interventions cannot be performed by running machine. The main switch must be turned off. Besides, a warning signal telling, "**DO NOT ACTIVATE - MACHINE IN MAINTENANCE**" must be clearly visible on the machine.



Attention: Any processing system, which may endanger the machine safety, must be avoided.



Attention: For replacement of oil, use a funnel with a filter in order to avoid that impurities enter into the gearbox or among the other movable parts and damage the good functioning of the machine.

Internal cleaning of the electric box is also needed and must be done like in the following:

- Turn off the machine moving the main switch on the electric box "0".
- Disconnect the mains supply from the electric board.
- Open the electric box lock.
- Do not use liquid detergents while cleaning the electric box inside.
- Check the connections to the terminals of the different devices.
- Tighten any loose connections.
- Close the door of the electric box and check if it is closed perfectly enough.
- Connect the electric board to the mains.
- Restart the machine according to the start procedure, and check if there are any anomalies because of faults or unintentional tampering during maintenance.

General Maintenance

The machine needs to be lubricating periodically for efficient working and longer to be lubricated periodically for efficient working and a longer life. You can see the points of lubrication list below and a lubrication chart for periods of lubricated

As the machine does not include any kind of hydraulic system, it is simple to lubricate its functional parts as shown in the below and back page.

Lubricate chart

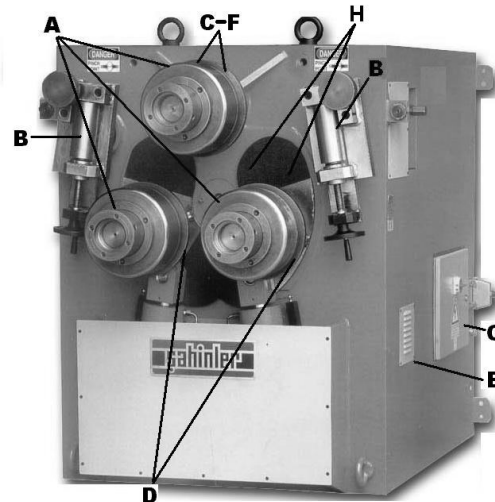

PART NO	CONTROL	WHAT TO DO	PERIOD
A	Rolls	Clean the rolls	Every work day
B	Guide rolls	Grease if necessary	Every Week
C	Top roll bushing	Grease and lubrication	Every month
D	Bottom rolls bushing	Grease and lubrication	Every month
E	Oil tank	Refill in necessary	Every year
F	Roller bearing	Grease	Twice a year
E	Oil tank	Complete hydraulic oil change with oil list	Once a year
G	Electric box	General cleaning	Once a year
H	Bottom rolls Back section	Grease	Every week



Note :

The rolls of the machine must **NEVER** be greased or lubricated. Because, then the rolls will slip the material and will not bend. Always keep the rolls clean and free from grease or any lubricant. Also make sure that the material is free from grease and dirt.

These points have all grease nipples marked with an **OIL** sign and must be greased periodically at least once a month or more if daily usage exceeds 8 hours a day.



Note :

That some of these points are actually inside the machine cover and the back cover must be removed in order to reach them. Any standard commercial grease can be used for lubrication.

Hydraulic maintenance

The machine has two bottom rolls that are adjustable with two hydraulic pistons which are operated with a simple but efficient almost maintenance free hydraulic unit. Also the rolls are powered by one hydraulic powered gearbox which are maintenance free as well. However at list once month we recommend you to remove the box cover and inspect any substantial oil leaks from the hydraulic unit or from the pistons.



Attention :

There can be a significant amount of oil if the machine is operated for the first time in horizontal mode. This is normal as the will probably leak from the top of the oil tank when turned the horizontal position.

Comparative hydraulic oil chart

The hydraulic tank cap of the machine air holes. Only during and immediately after transport and when the machine works in horizontal position there may be visible oil leak from the bottom. There is nothing wrong with the machine and this oil is not important. It is only the excess oil from the tank. The machine will still operate normally.

On most of our machines hydraulic systems we use "GRADE 32" hydraulic mineral oil and "GRADE 46" hydraulic oil. Generally we recommend the use of "SHELL TELLUS NR. 46" and "BP ENERGOL NR. 46" for hydraulic system.

Brand	DIN 51524 Specification 32 Grade Mineral Oil	DIN 51524 Specification 46 Grade Mineral Oil
	32 Grade Mineral Oil	46 Grade Mineral Oil
Agip	OSO 32	OSO 46
BP	Energol HLP 32	Energol HLP 46
Castro	Hyspin AWS 32	Hyspin AWS 46
Elf	Elfolna 32	Elfolna 46
Esso	Nuto H 32	Nuto h 46
Fina	Hydran 32	Hydran 46
IP	Hydrus 32	Hydrus 46
Mobil	DTE 24	DTE 25
Q8	Haydn 32	Haydn 46
Shell	Tellus 32	Tellus 46
Texaco	Rando HD 32	Rando HD 46
Total	Azolla ZS 32	AzollaZS 46

Reduction gearbox maintenance

The reduction gearbox used in the machine are hydraulic motor powered and are completely maintenance free. However a periodical on the outside will make sure it runs properly. They are placed inside the machine and clearly visible when the back cover is open. Check and secure any loose bolts if necessary.

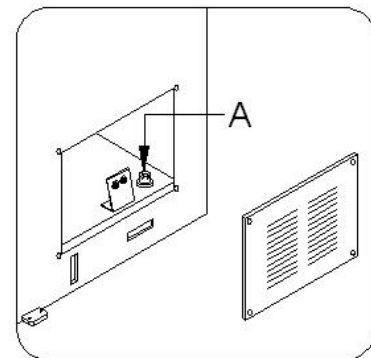
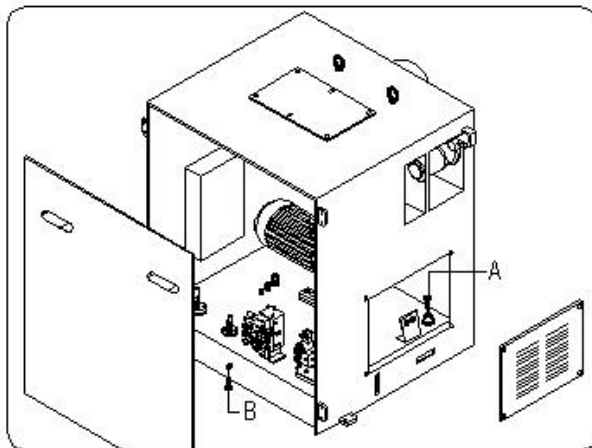

Check of the hydraulic system

Check the hydraulic oil level (B) and replace with hydraulic if necessary. We recommend the use number 46 of shell Tellus hydraulic oil or any equivalent from any other brand. Oil can be removed from the tank by removing the cap under the oil gauge (B). Also if necessary replace the filter if the clog indicator is red (A). Shown as above.

LUBRICATING THE GUIDE ROLLERS

The Guide Rollers must also be lubricated periodically. Use a greasing pump for lubrication

Change to reinforcing wheel position;

- loosen the set screws (A) by turning it to counter-clockwise
- Change the position of the reinforcing wheel by pulling towards the arrow as shown in figure 1

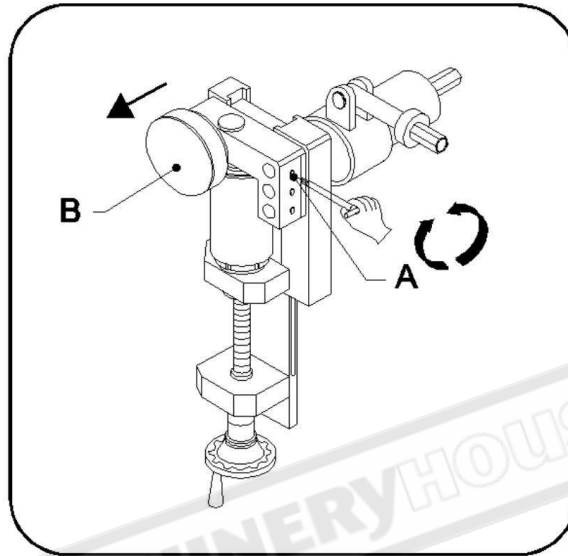

figure 1

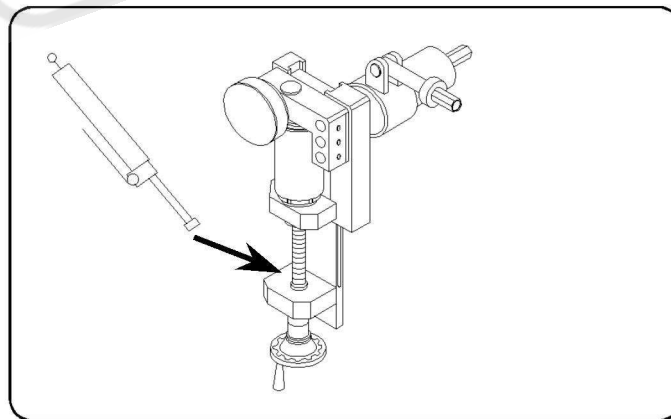

figure 2



Attention : The machine must be powered off before any maintenance



Clutch System;

If the top roll stops, while lower rolls are turning, than the pressure springs must be tightened a bit. To make this you have to screw the setscrews shown in Step2.

The balance of the clutch system is shown below step by step.

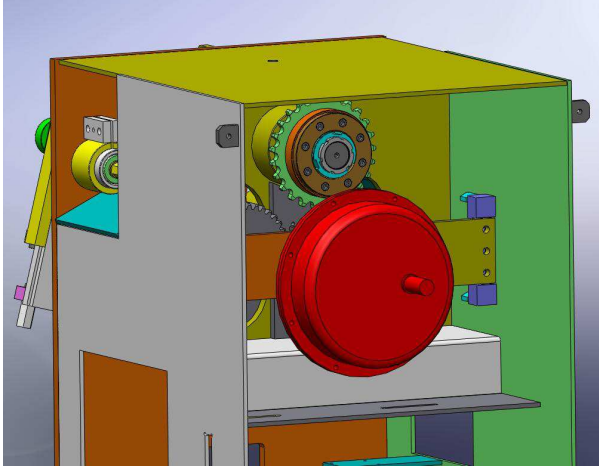

Step1

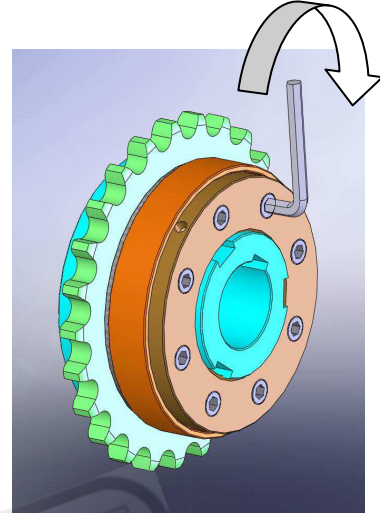

Step2

1. Open the back cover.
2. Screw them through arrow direction with an ally key.(10)



Note : Keep to tighten it until top roll begins to turn.

HYDRAULIC PLAN

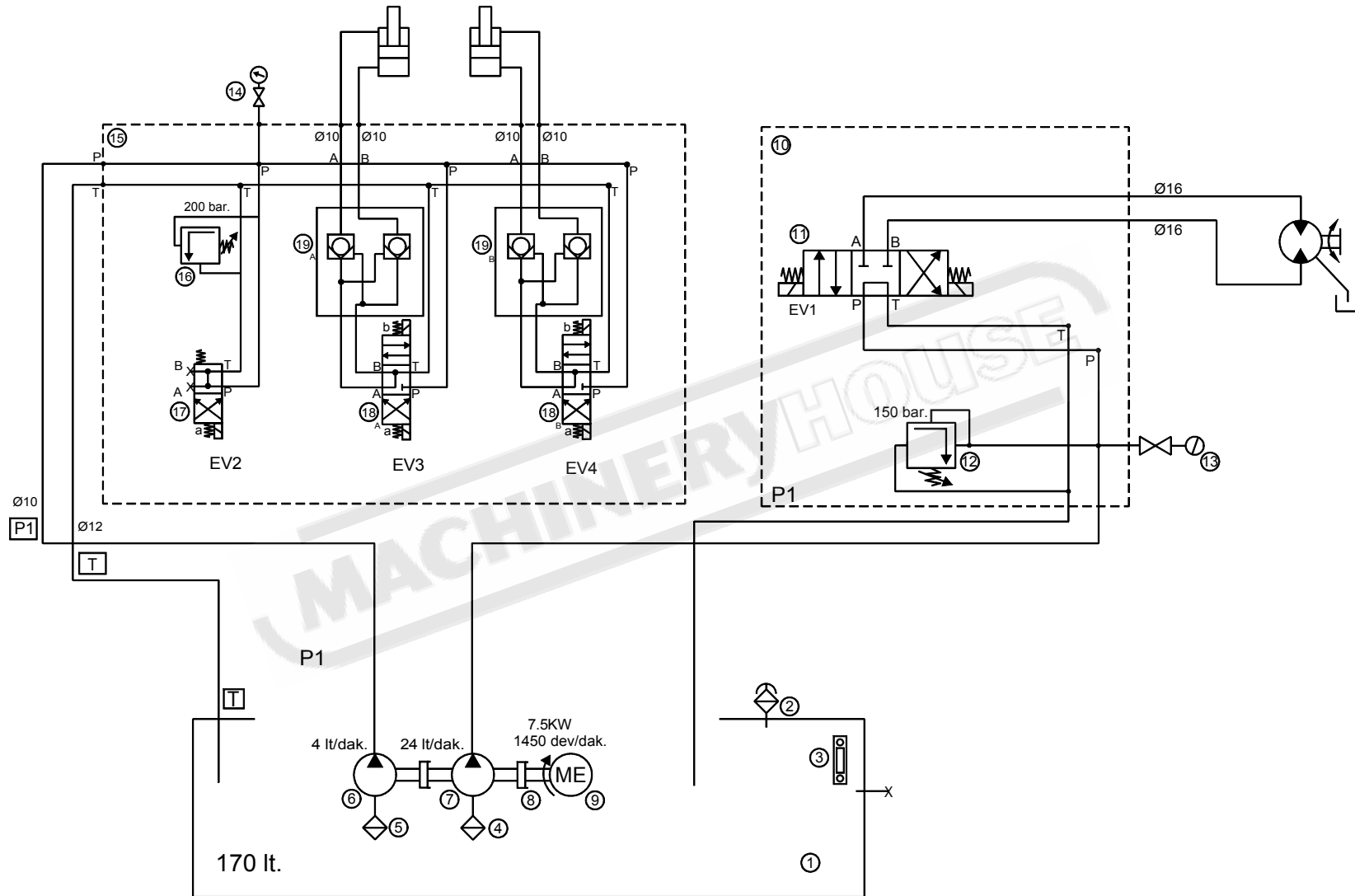

PAGE NO	HPK 100	HYDRAULIC PLAN	DATE	Plan No	FILE NAME	ŞAHİNLER METAL MAKİNA ENDÜSTRİ A.Ş.
1			24.10.2007	00-14	Hpk100-Hidplan	



HPK 100 HYDRAULIC PLAN

NR.	PART NAME	CODE	BRAND	QTY.
1	Hydraulic Block	T 170	ŞAHİNLER	1
2	Oil cap	-	-	1
3	Oil level gauge	FS 127	UCC	2
4	Sucking Filter	45 lt	GEMFA	1
5	Sucking Filter	125 lt	GEMFA	1
6	Gear pump	1D4RO	MARZOCCHI	1
7	Gear pump	2D24RO	MARZOCCHI	1
8	Couplin	1K300-DK 42		1
9	Motor (7,5 kW)	132 S4C	WAT	1
10	Hydraulic Unit	Ü 100	ŞAHİNLER	1
11	Direction valve	D3W8CJJ23	PARKER	1
12	Pressure Saffety Valve	RM3PT35S	PARKER	1
13	Manometer	0-400 BAR	PAKKENS	1
14	Manometer	0-400 BAR	PAKKENS	1
15	Hydraulic Block	Ü 101	ŞAHİNLER	1
16	Pressure Saffety Valve	RM2PT35S	PARKER	1
17	Direction valve	D1VW2KNJP75	PARKER	1
18	Direction valve	D1VW4CNJP75	PARKER	2
19	Twin lock Valve	CPOM2DD	PARKER	2

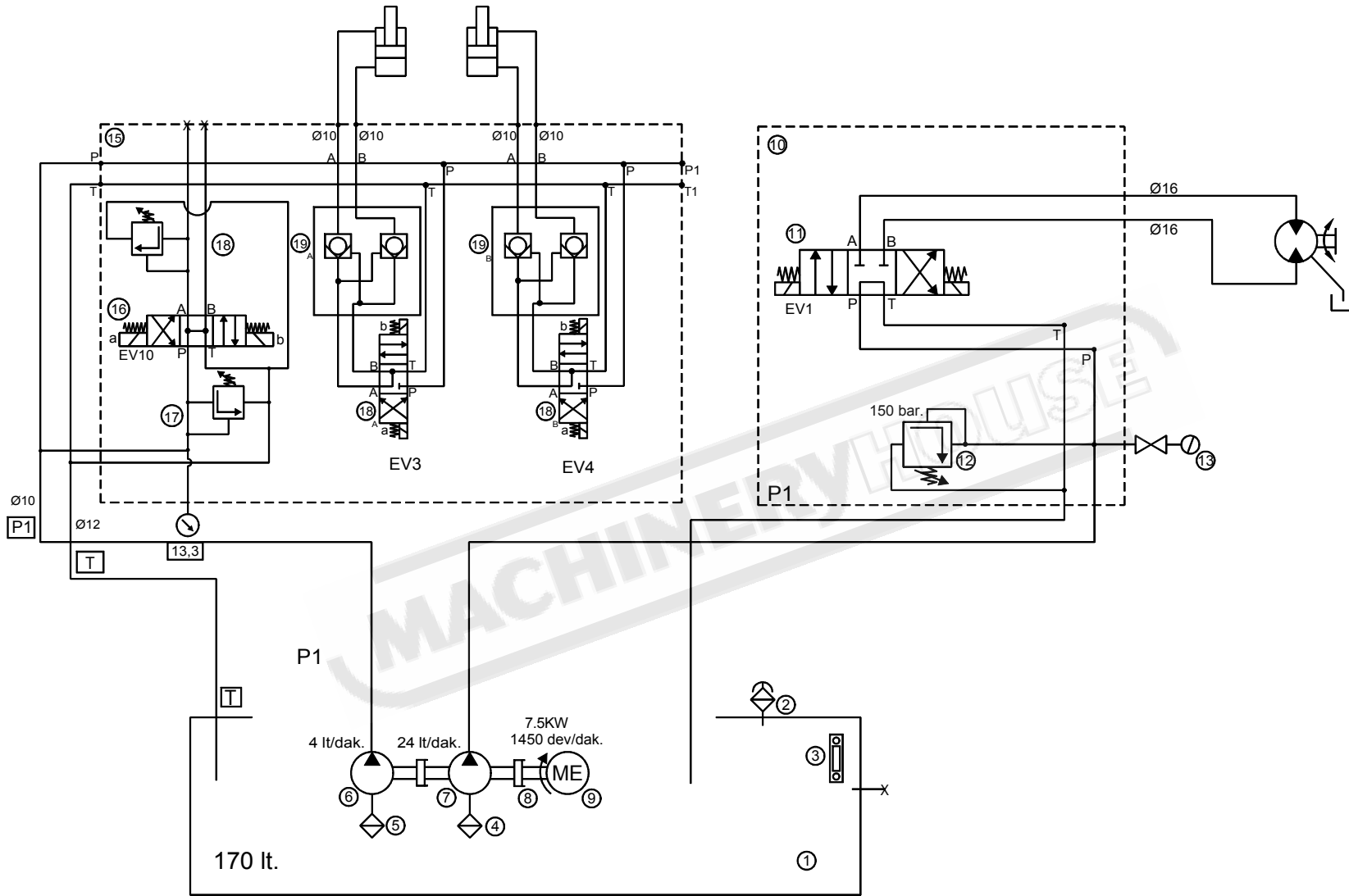

Sayfa No	HPK 100	HYDRAULIC PLAN	Tarih	Plan No	Dosya Adı	ŞAHİNLER METAL MAKİNA ENDÜSTRİ A.Ş.
01			01-02-2016	01-02-16	hid-yan-day	

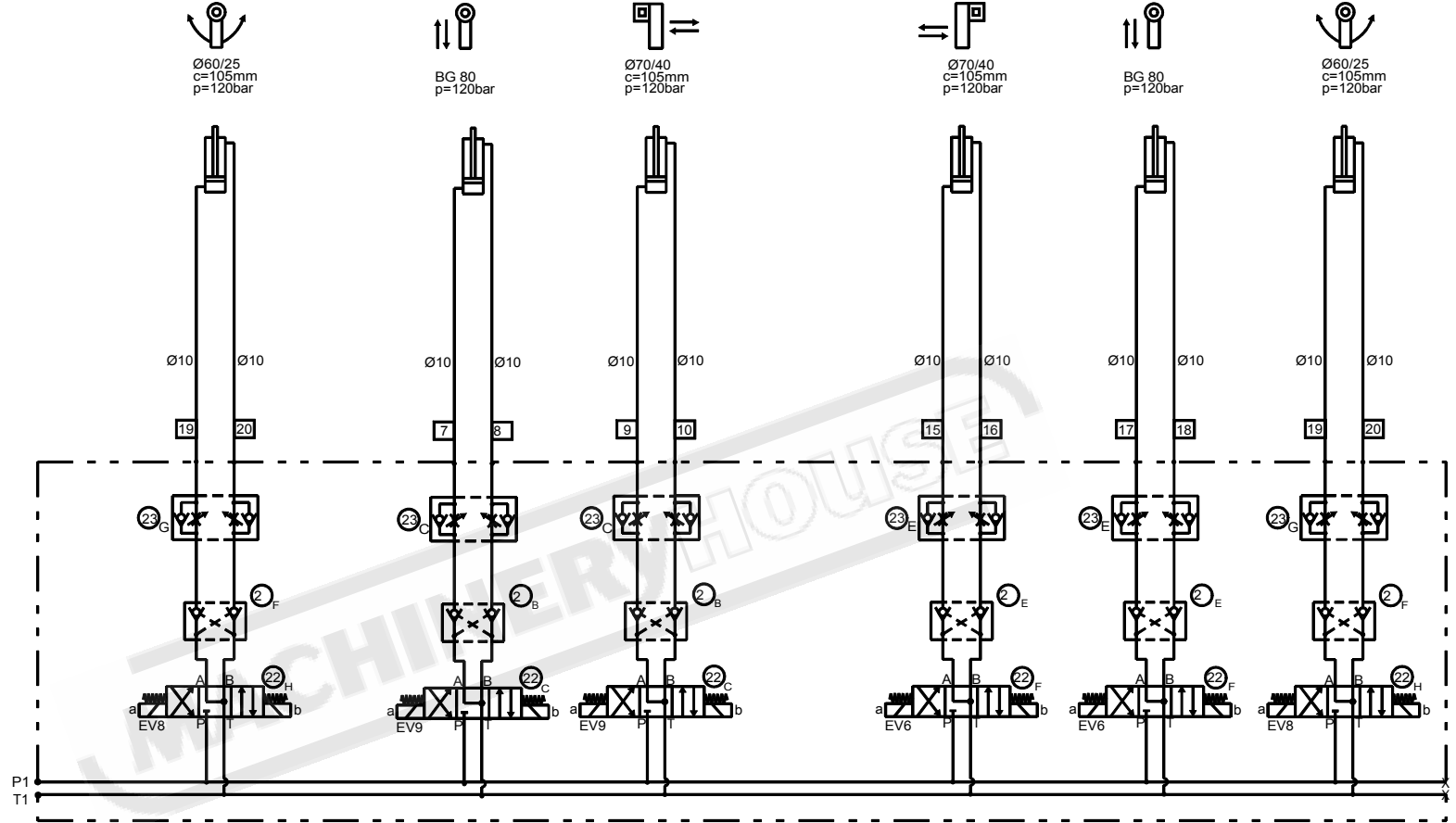

Sayfa No	HPK 100	HYDRAULIC PLAN	Tarih	Plan No	Dosya Adı	ŞAHİNLER METAL MAKİNA ENDÜSTRİ A.Ş.
02			01-02-2016	01-02-16	hid-yan-day	

DRIVEN SHAFT GROUP

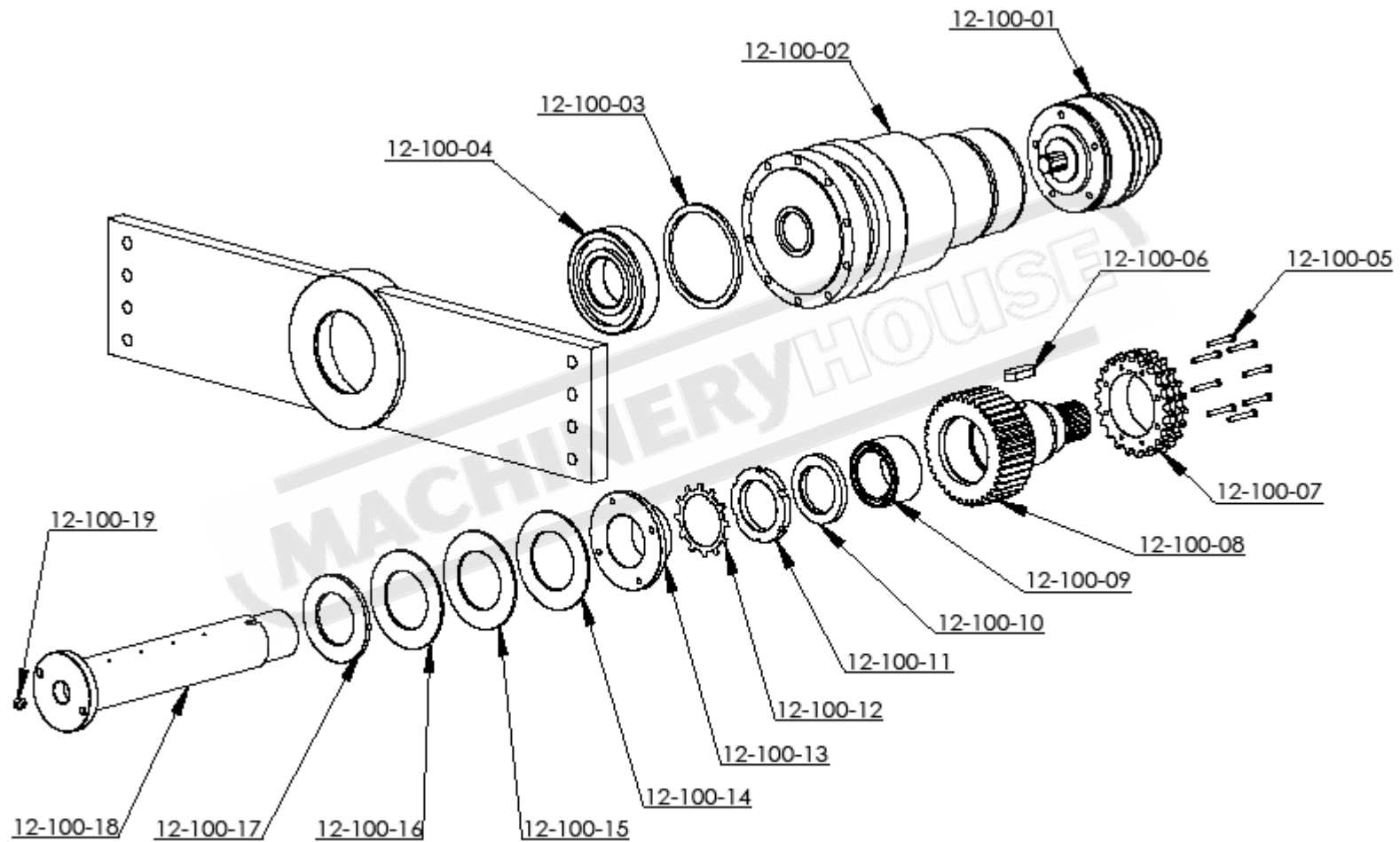

TOP ROLL SHAFT GROUP

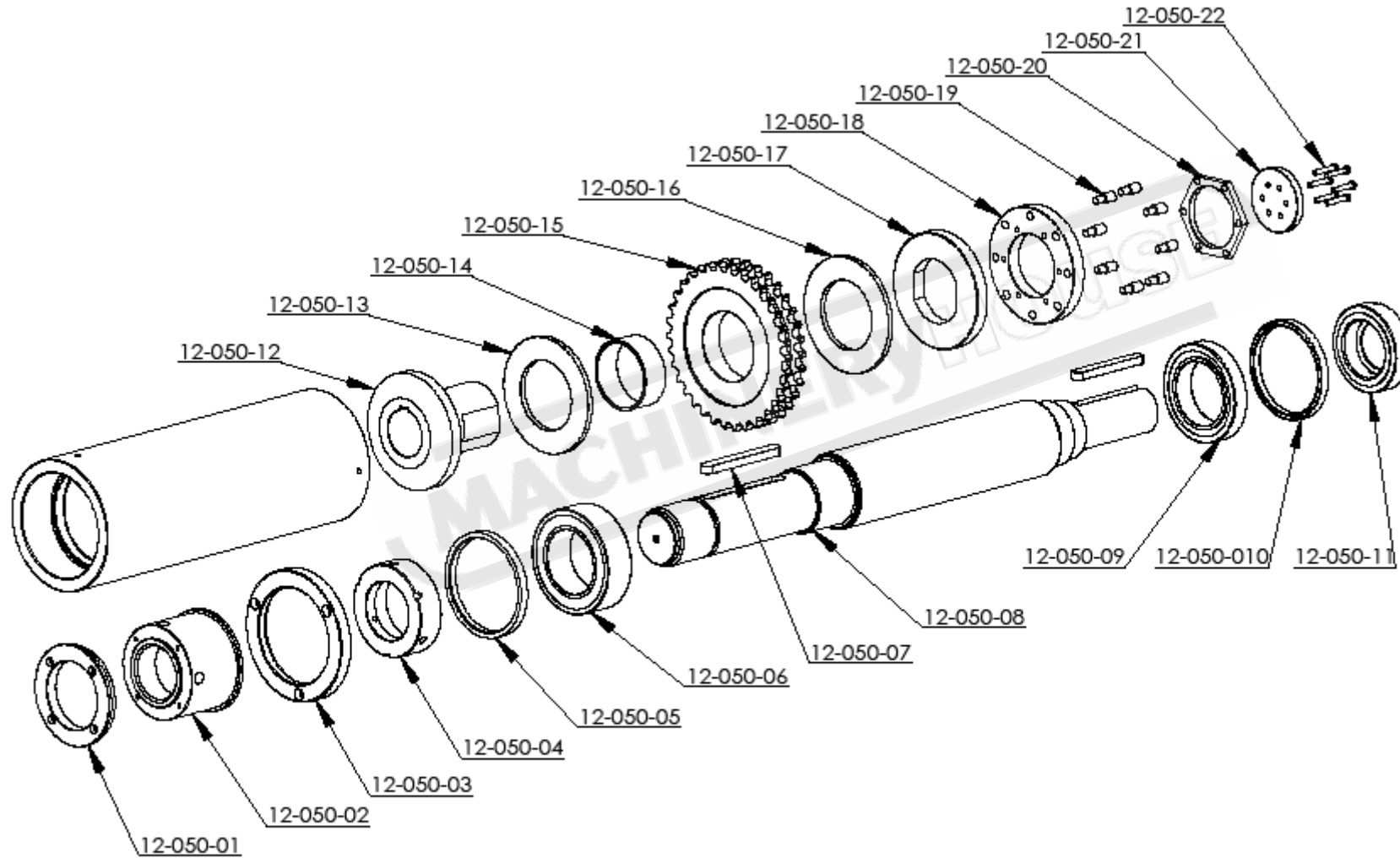

BOTTOM ROLL SHAFT GROUP

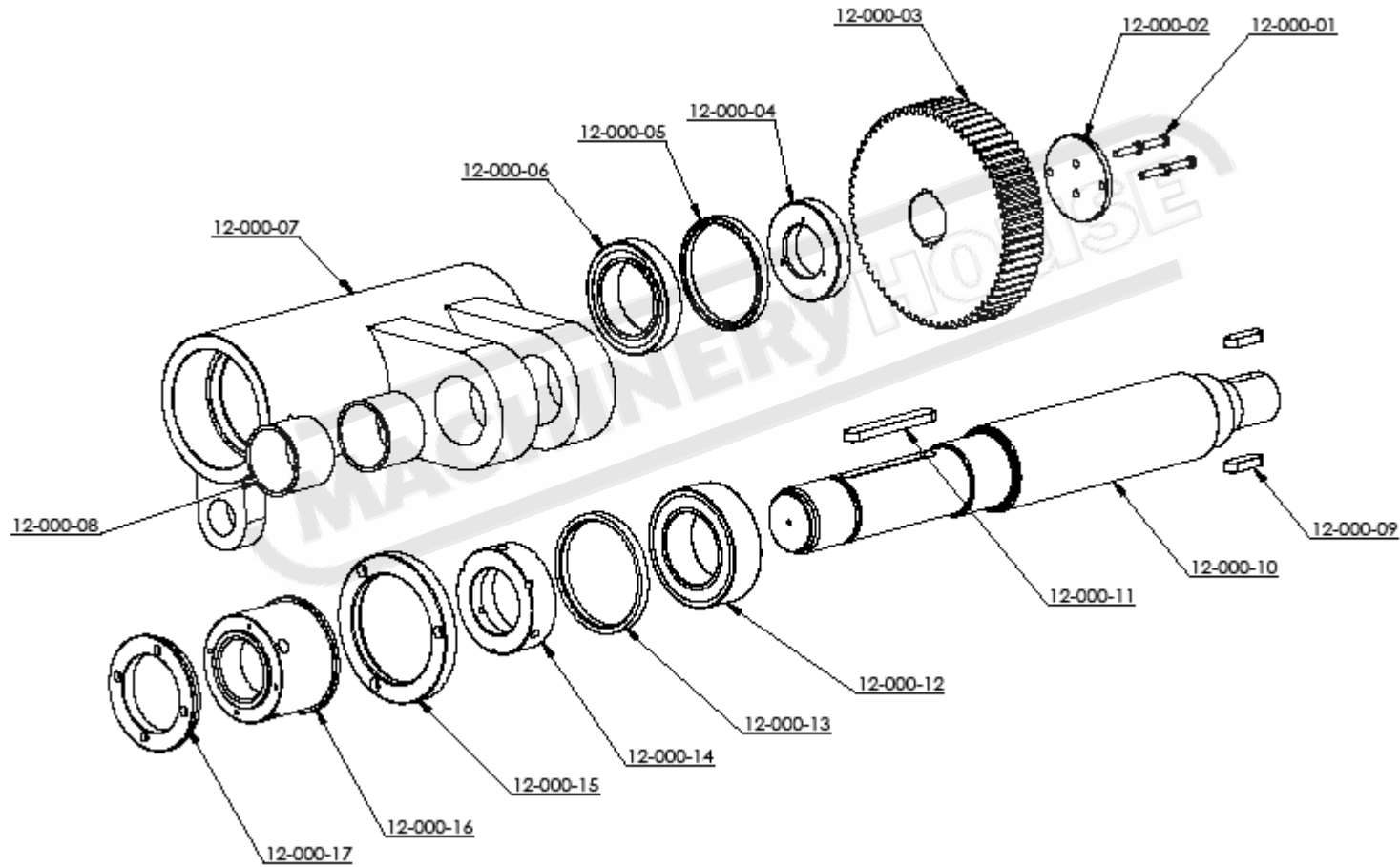

GUIDE ROLLER GROUP

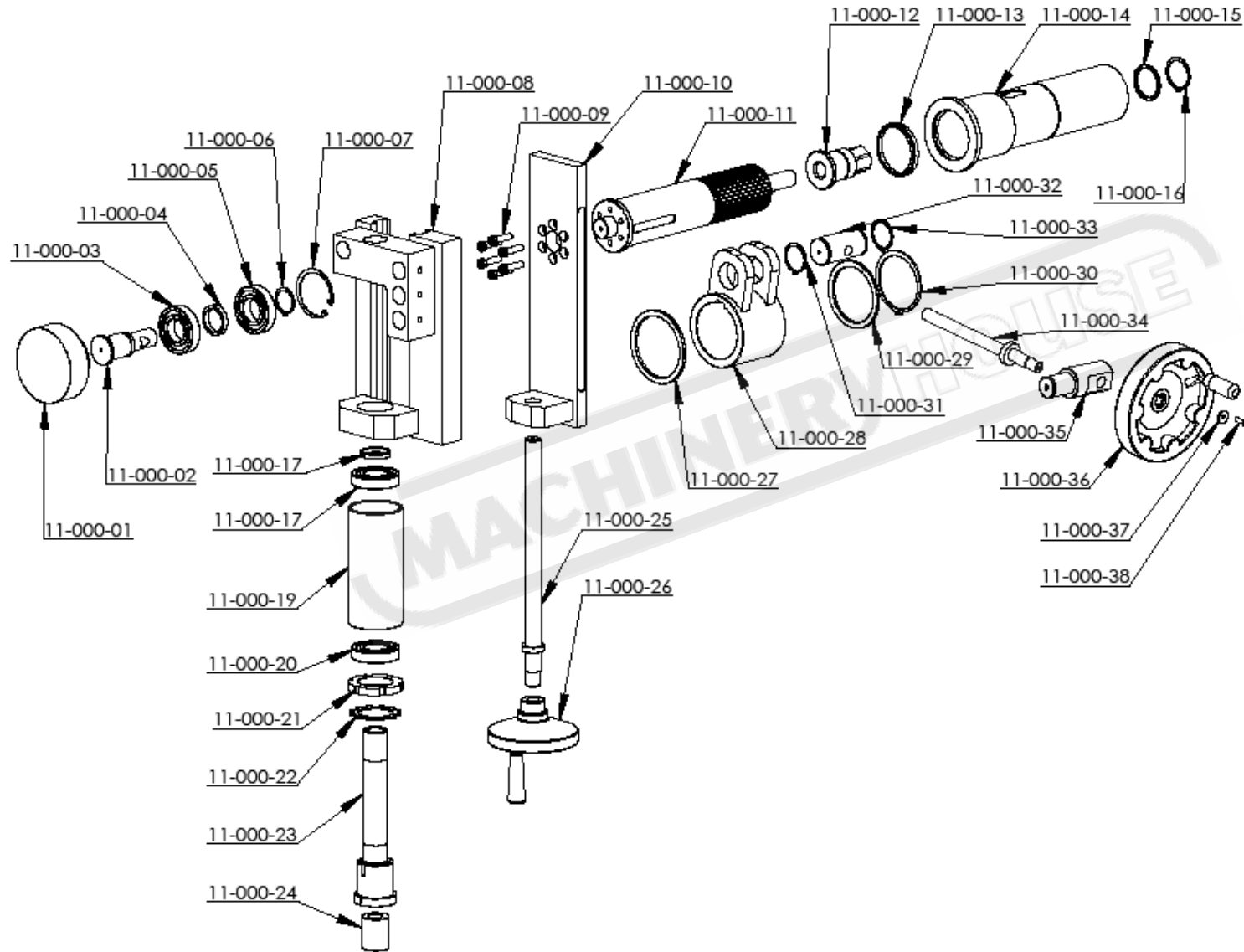



PISTON GROUP

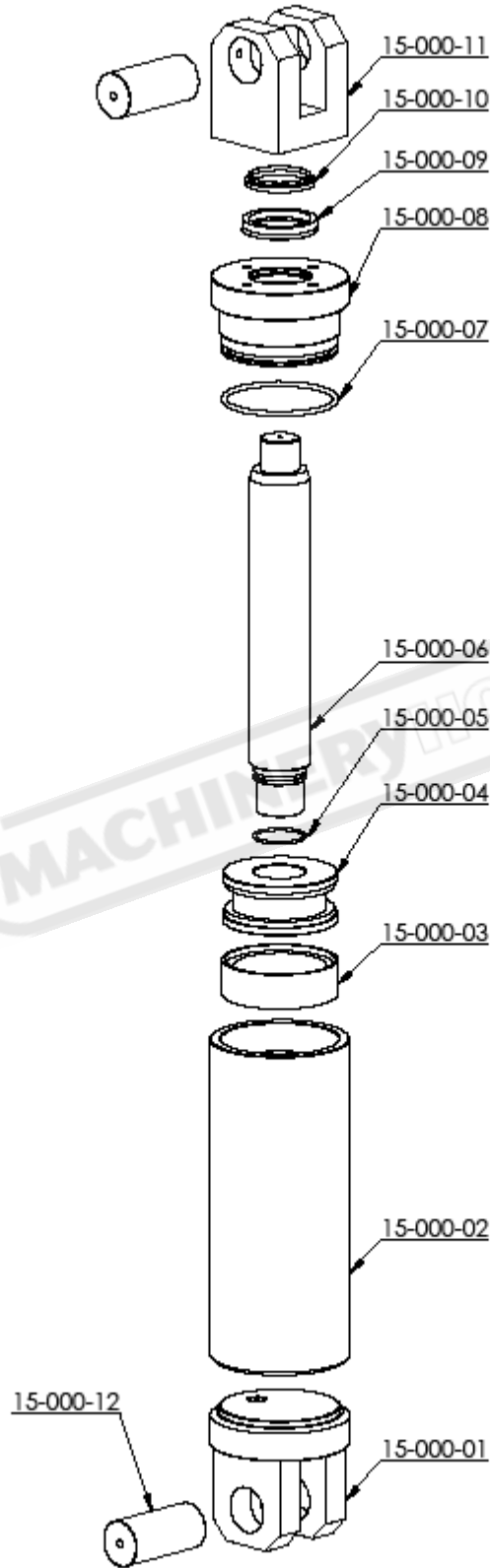

sahinler

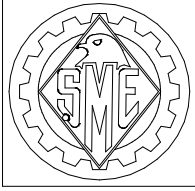

ŞAHINLER METAL MAKİNA ENDÜSTRİ A.Ş.

Izmir Yolu 22. km. Mümin Gençođlu Caddesi
16285 BURSA/TÜRKİYE
Tel. (+90 224)470 01 58 (PBX - 6 Hat/Line)
Fax.: (+90 224)470 07 70 - 470 09 05
www.sahinlermetal.com email: info@sahinlermetal.com

Customer :
Project name : HPK-100 HYDRAULIC SECTION BENDING MACH. NC
Drawing number : 28022018
Customer's address:

Manufacturer SAHINLER METAL MAKİNA ENDÜSTRİ A.Ş.

File name (\EPLAN4\P): HPK1159
Drawn by : HUSEYİN KARADUMAN
Checked by : FIRAT CİLİNGİR
Responsible for project : FIRAT CİLİNGİR

Start Date : 08. Mar. 2022 The Last Page : 16
Complete Date : Total page : 16

Date	30. Nov. 2022	HPK 100 NC
Drawn by	HUSEYİN KARADUMAN	
Checked by	FIRAT CİLİNGİR	
Norm	Original	

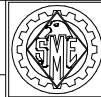

sahinler
METAL MAKİNA
ENDÜSTRİ A.Ş.

COVER SHEET

Drawing number: 28022018

File number:
HPK1159Project name:
HPK1159P. 1
16 P.

1	COVER SHEET	14. Jan. 2021
2	Table of contents	14. Jan. 2021
3	MOTOR GROUP	28. Feb. 2018
4	CONTROL GROUP	14. Jan. 2021
5	A1 GROUP - 1	28. Feb. 2018
6	A1 GROUP - 2	28. Feb. 2018
7	A2 GROUP - 1	28. Feb. 2018
8	A3 GROUP - 1	28. Feb. 2018
9	A3 GROUP - 2	28. Feb. 2018
10	ENCODER GROUP	29. Apr. 2014
11	COMMUNICATION CONNECTIONS	28. Feb. 2018
12	CONNECTOR PLAN	28. Feb. 2018
13	ELECTRICAL PARTS LIST - 1 INSIDE THE CABINET	14. Jan. 2021
14	ELECTRICAL PARTS LIST - 2 ON THE CONTROL PANEL	14. Jan. 2021
15	ELECTRICAL PARTS LIST - 3 ON THE MACHINE	14. Jan. 2021
16	ELECTRICAL CABINET SCHEME	14. Jan. 2021



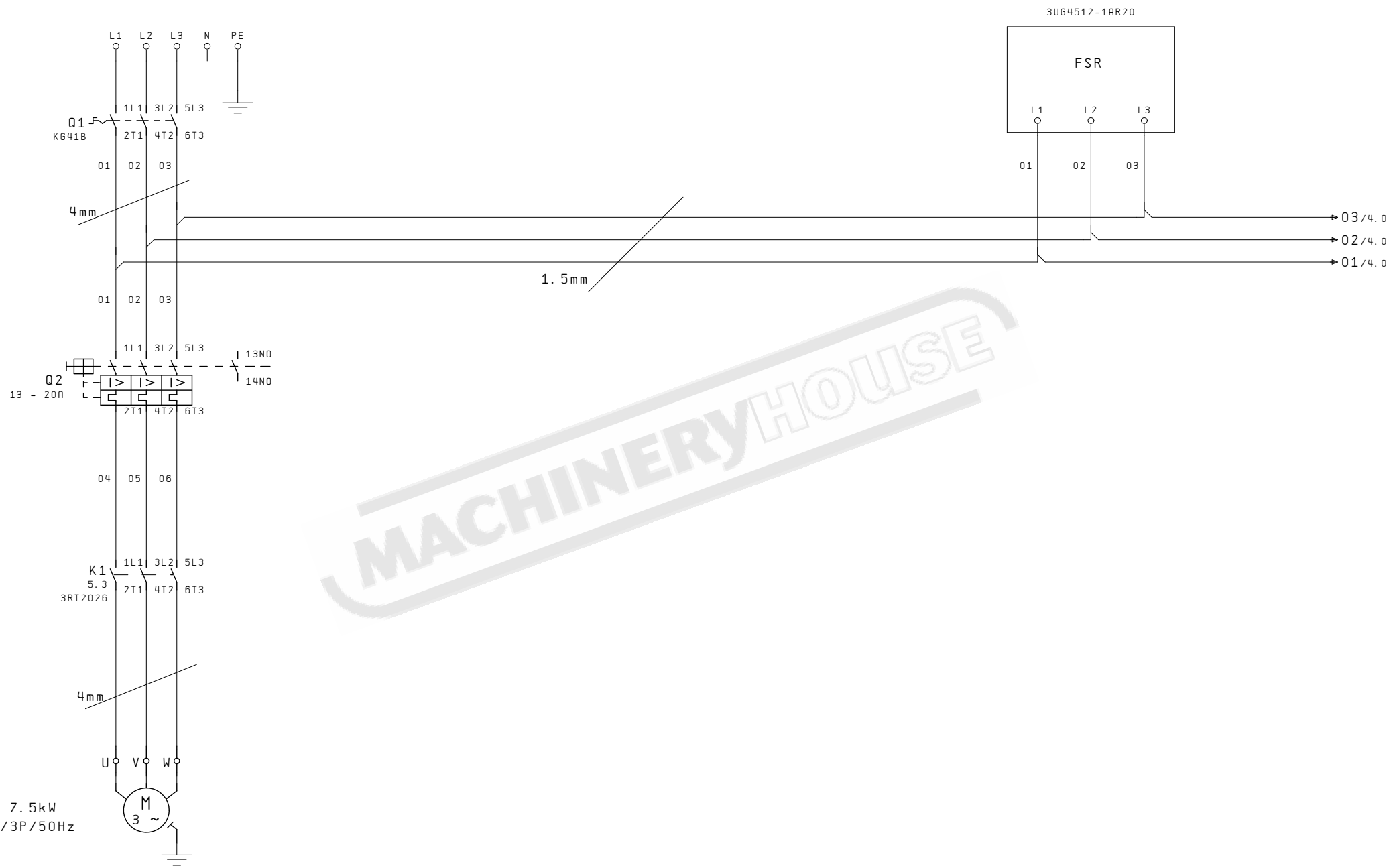

Date	30. Nov. 2022	HPK 100 NC	 Sahinler METAL MAKINA ENDUSTRI A. S.	MOTOR GROUP	Drawing number: 28022018	=	
Drawn by	HUSEYIN KARADUMAN					File number: HPK1159	+
Checked by	FIRAT CILINGIR					Project name: HPK1159	
Norm		Original					
							P. 3
							16 P.

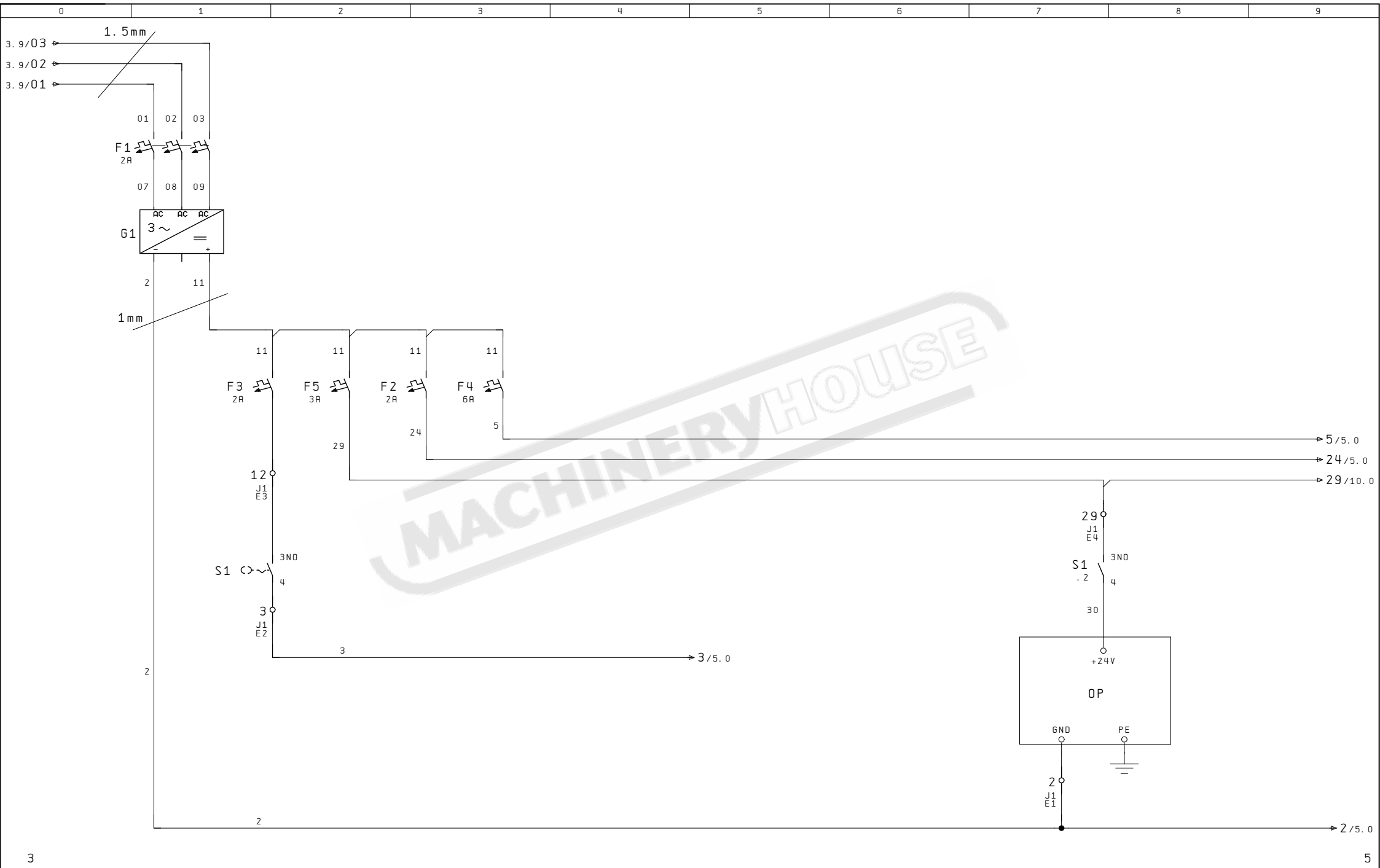

MACHINERY HOUSE

Date	30. Nov. 2022	HPK 100 NC	 Sahinler METAL MAKINA ENDUSTRI A. S.	CONTROL GROUP	Drawing number: 28022018			
Drawn by	HUSEYIN KARADUMAN					File number:	Project name:	P. 4
Checked by	FIRAT CILINGIR					HPK1159	HPK1159	16 P.
Norm		Original						

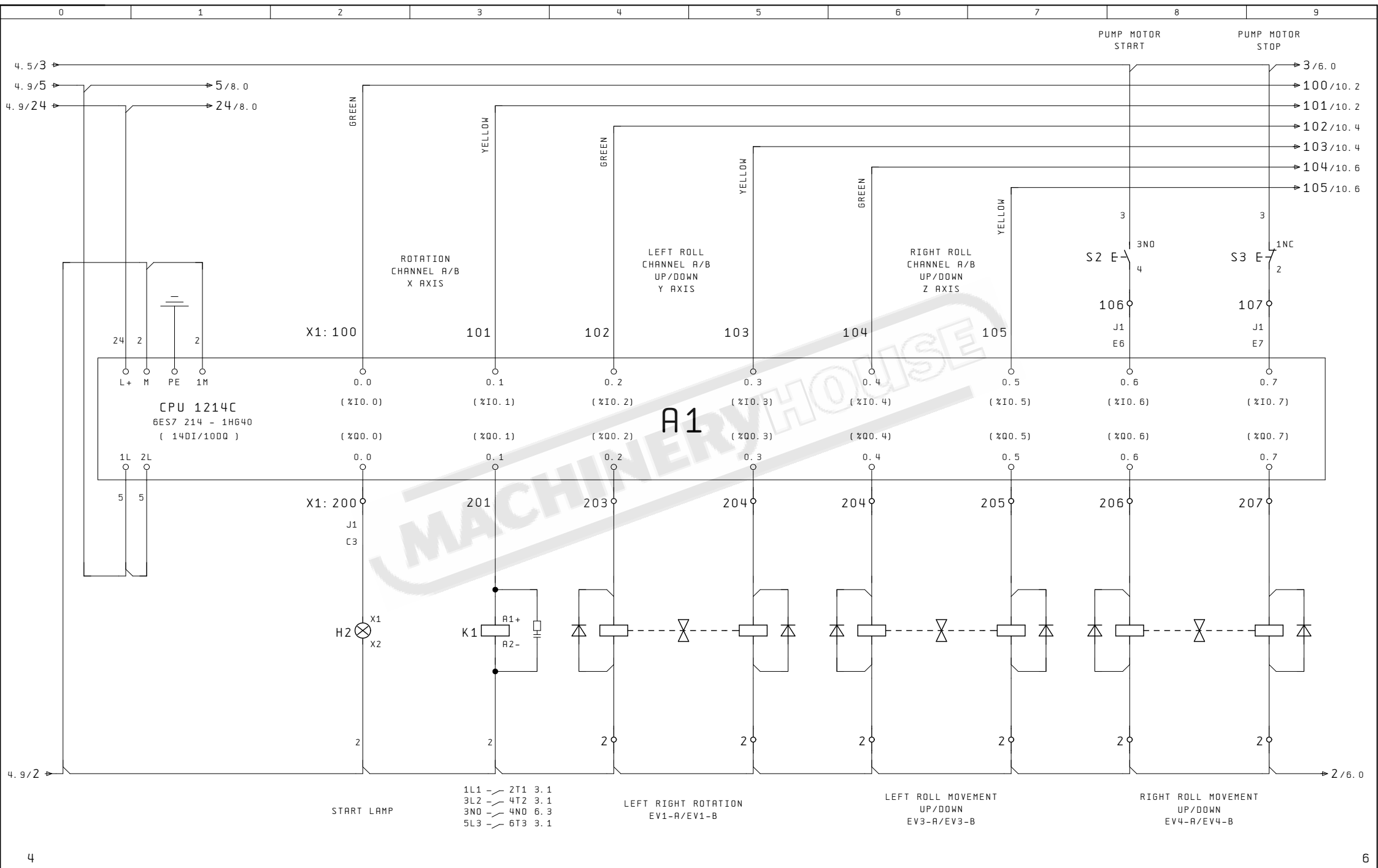

Date	30. Nov. 2022	HPK 100 NC	 Sahinler METAL MAKINA ENDUSTRI A. S.	A1 GROUP - 1	Drawing number: 28022018	=	
Drawn by	HUSEYIN KARADUMAN					File number: HPK1159	+
Checked by	FIRAT CILINGIR					Project name: HPK1159	
Norm		Original					
						P. 5	
						16 P.	

EMERGENCY STOP PHASE SEQUENCE RELAY OVERLOAD THERMAL RELAY MOTOR PUMP MOTOR CONTACTOR ON 24V DC ON PNEUMATIC PISTON MATERIAL STARTUP POSITION

5.9/3 → 3/7.0

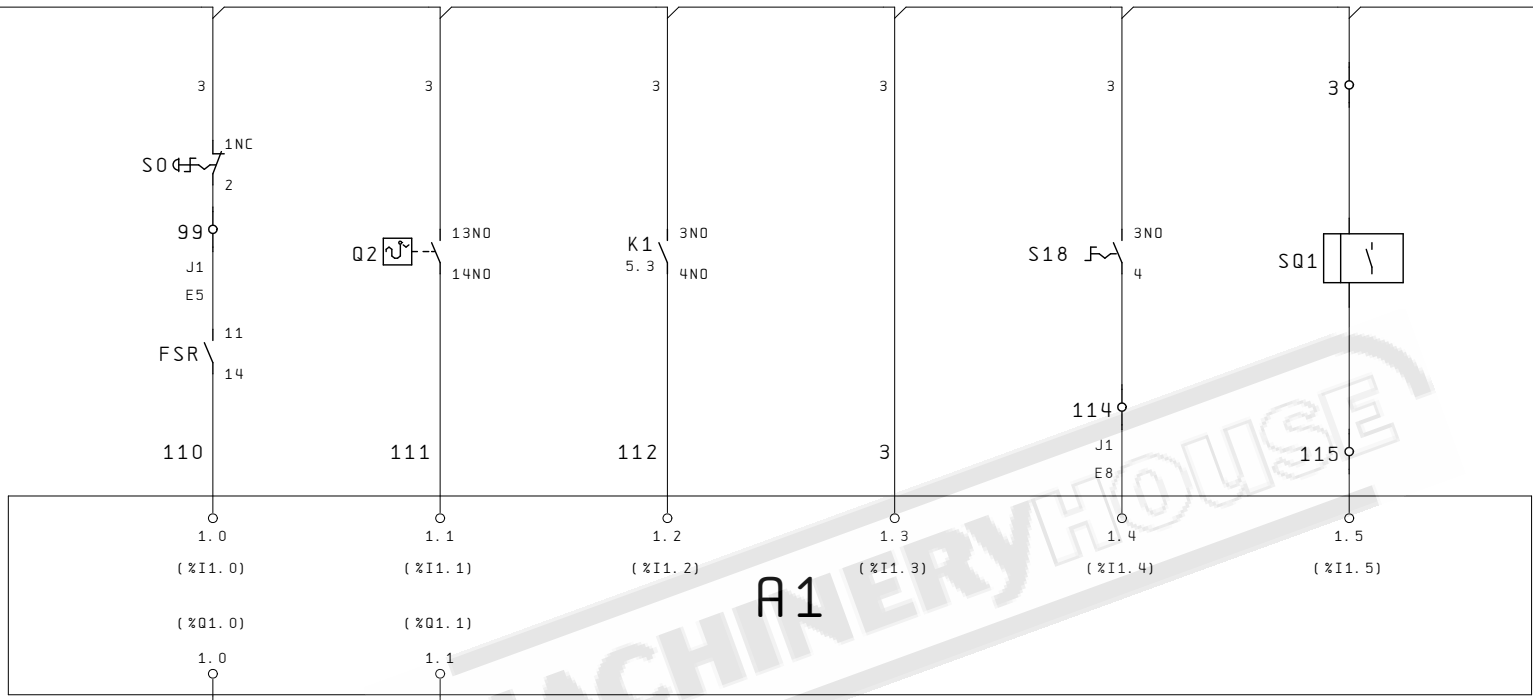

A1

5.9/2 → 2/7.0

MAIN VALVE - 1 (ROLL MOVEMENTS) EV2-A PNEUMATIC PISTON EV11

Date	30. Nov. 2022	HPK 100 NC	 Sahindar METAL MAKINA ENDUSTRI A. S.	A1 GROUP - 2	Drawing number: 28022018	=	
Drawn by	HUSEYIN KARADUMAN				File number: HPK1159	Project name: HPK1159	+
Checked by	FIRAT CILINGIR	Original					
Norm							
					P. 6		
					16 P.		

LEFT ROLL MOVEMENT
UP/DOWN

RIGHT ROLL MOVEMENT
UP/DOWN

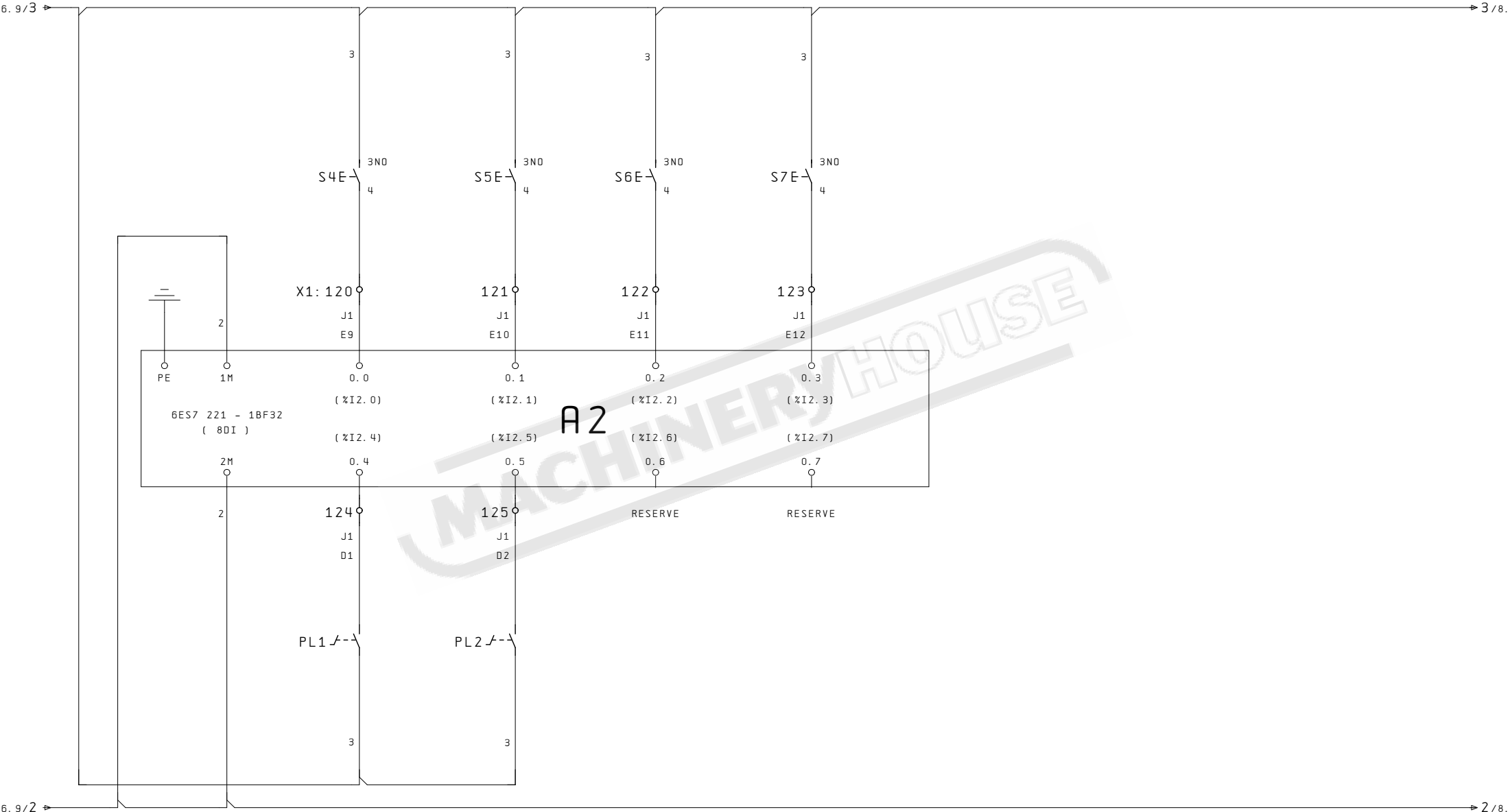

LEFT ROTATION RIGHT ROTATION

Date	30. Nov. 2022	HPK 100 NC	 Sahinler METAL MAKINA ENDUSTRI A. S.	A2 GROUP - 1	Drawing number: 28022018	=	
Drawn by	HUSEYIN KARADUMAN					+	
Checked by	FIRAT CILINGIR					File number: HPK1159	Project name: HPK1159
Norm		Original				P. 7	16 P.

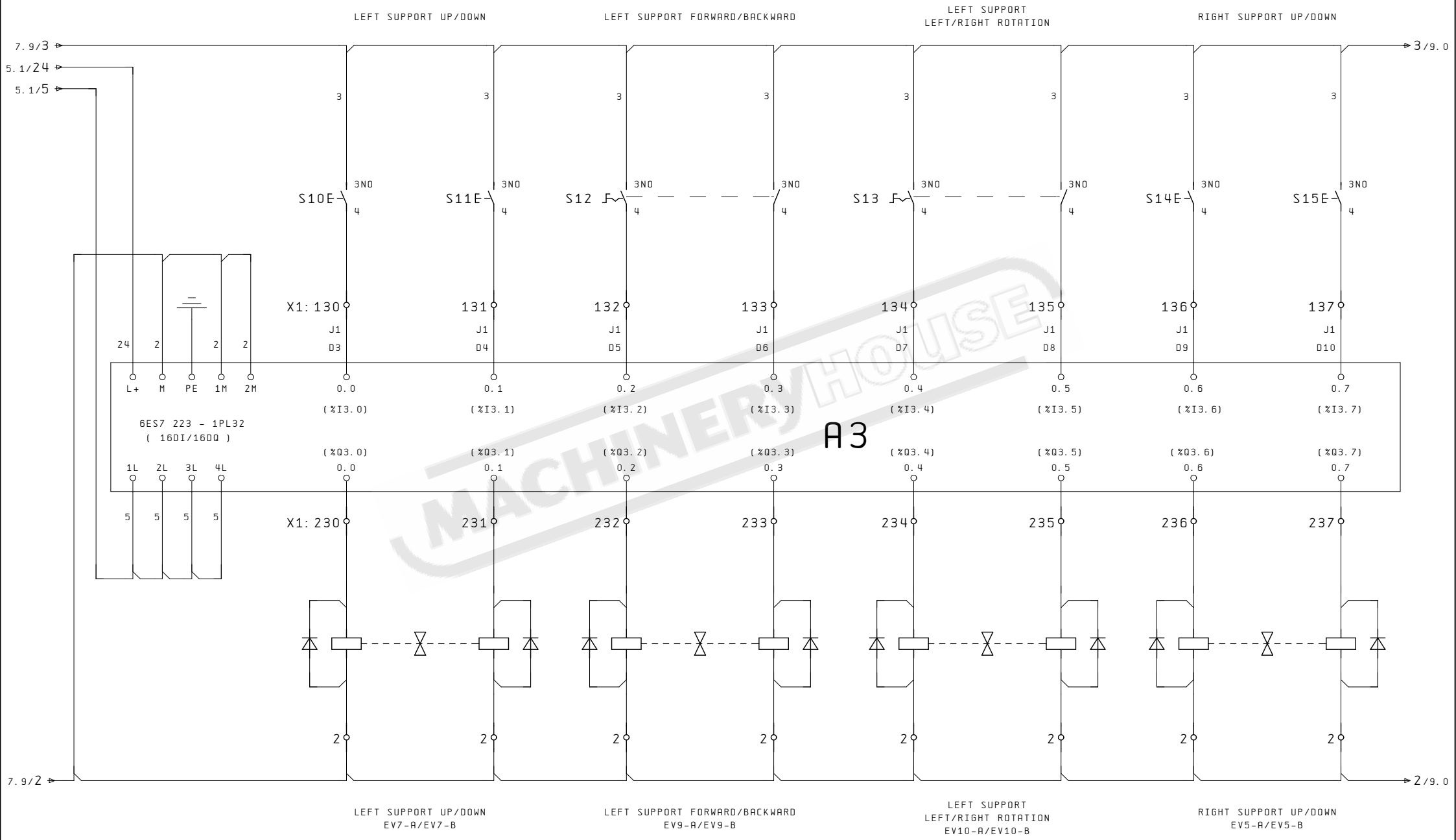

Date	30. Nov. 2022	HPK 100 NC		A3 GROUP - 1	Drawing number: 28022018	=	
Drawn by	HUSEYIN KARADUMAN				File number: HPK1159	Project name: HPK1159	+
Checked by	FIRAT CILINGIR	Original					P. 8
Norm							16 P.

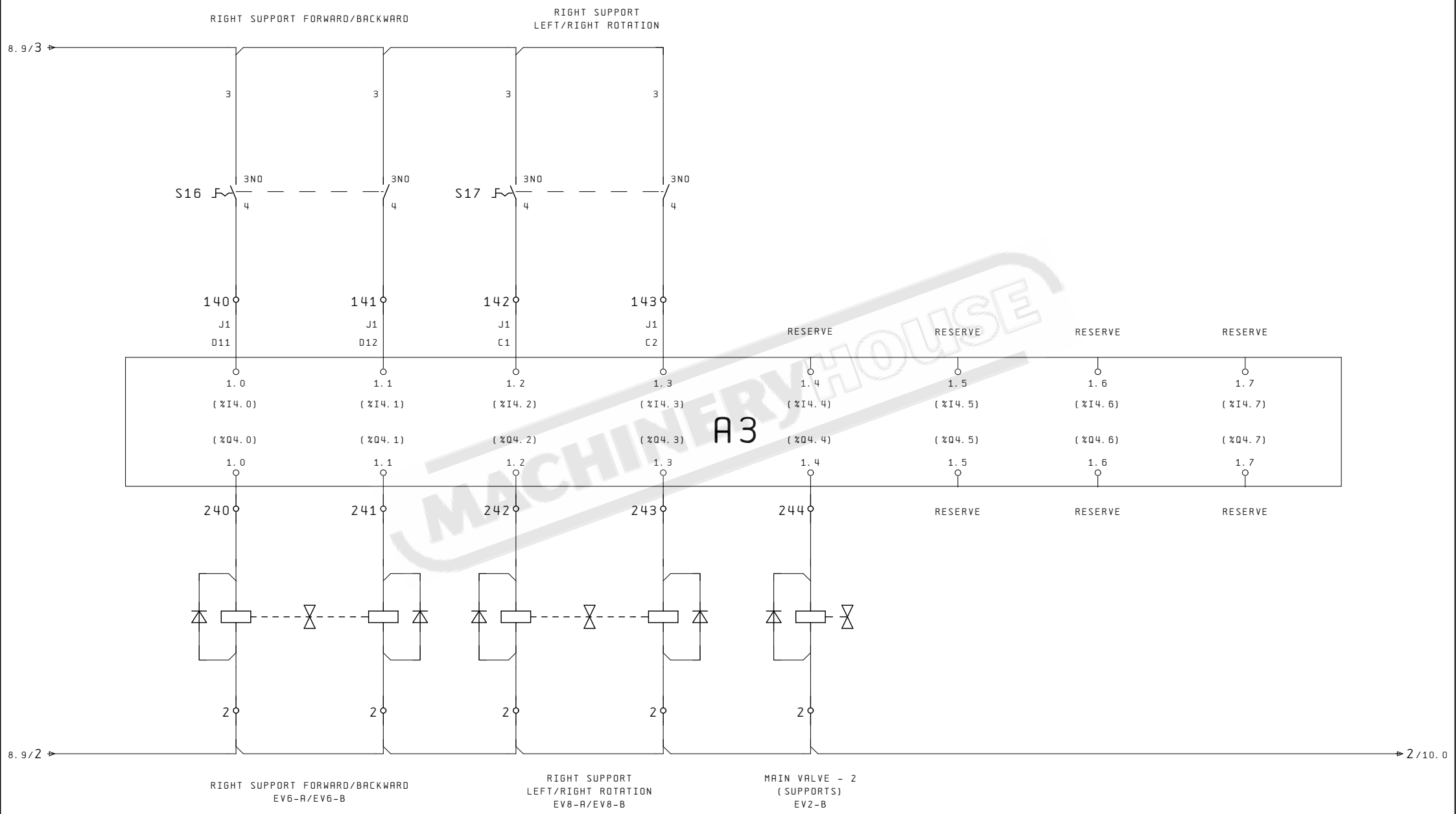

Date	30. Nov. 2022	HPK 100 NC	 Sahinler METAL MAKINA ENDUSTRI A. S.	A3 GROUP - 2	Drawing number: 28022018	=	
Drawn by	HUSEYIN KARADUMAN				File number: HPK1159	Project name: HPK1159	+
Checked by	FIRAT CILINGIR	Original					
Norm							
						P. 9	
						16 P.	

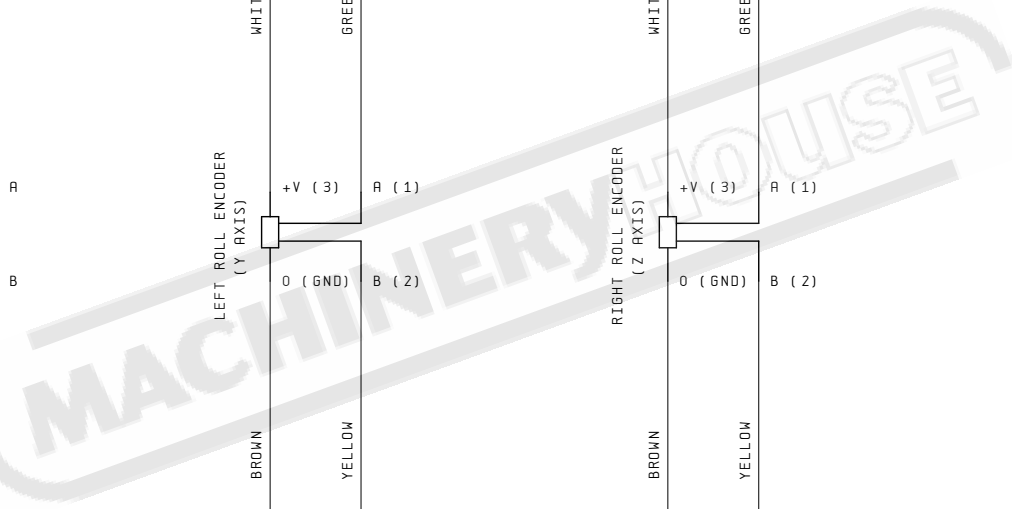
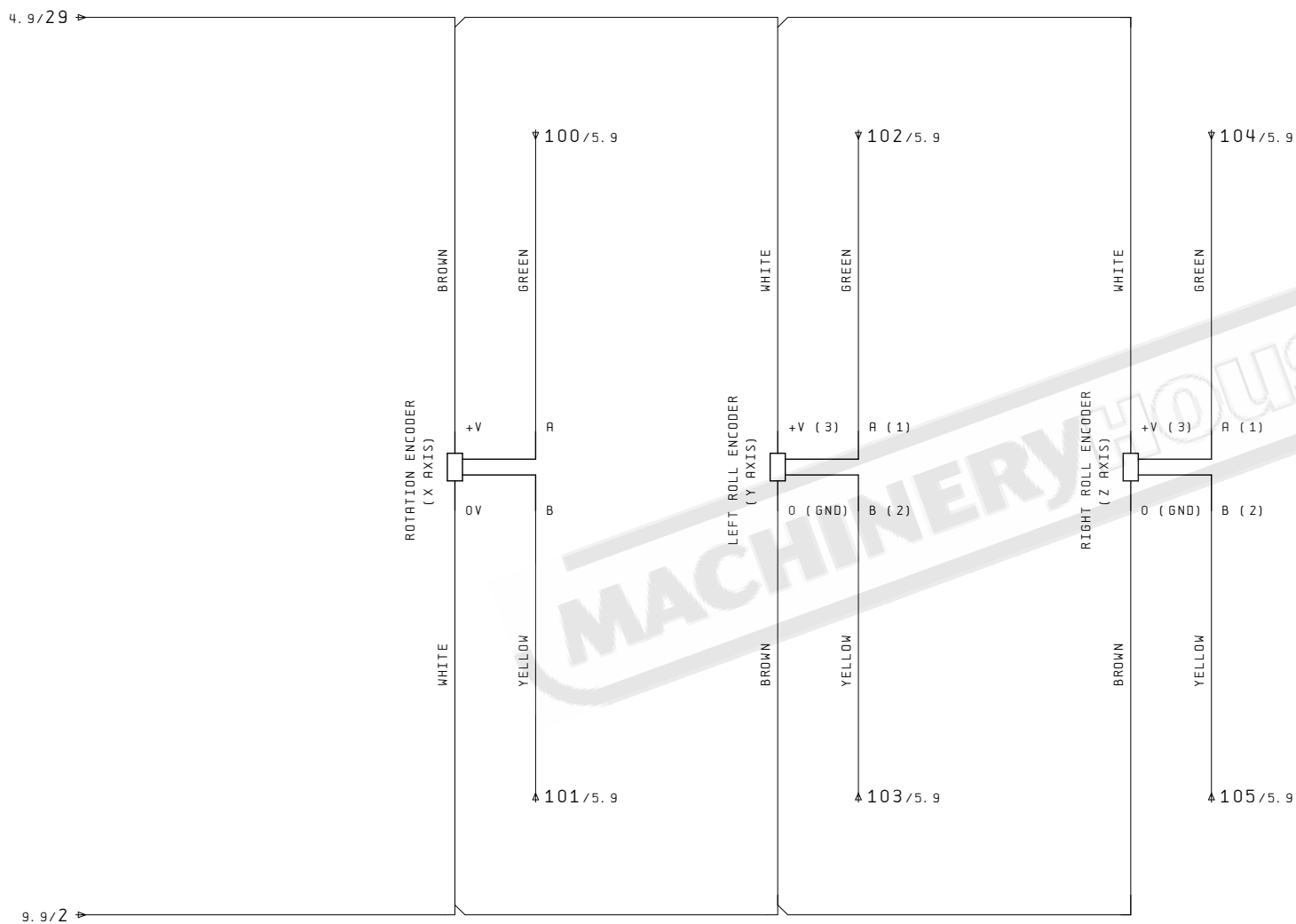

Date	30. Nov. 2022	HPK 100 NC	 METAL MAKINA ENDUSTRI A.S.	ENCODER GROUP	Drawing number:	28022018	=		
Drawn by	HUSEYIN KARADUMAN				File number:	HPK1159	Project name:	HPK1159	+
Checked by	FIRAT CILINGIR								
Norm	Original								

OPERATOR PANEL
RJ45 PORT
LAN1

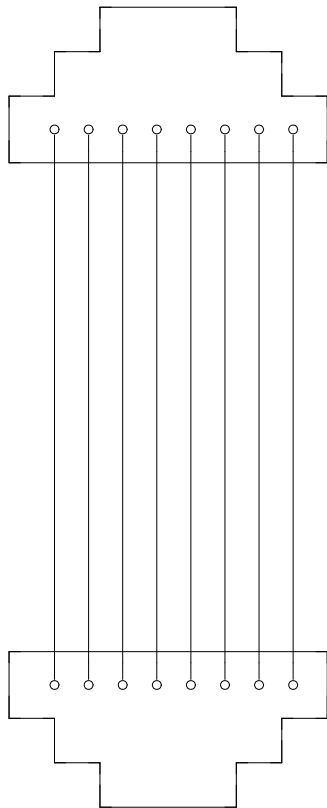

PLUG HOUSING
19410100522
B

PLUG IN HOUSING
19410100301
B

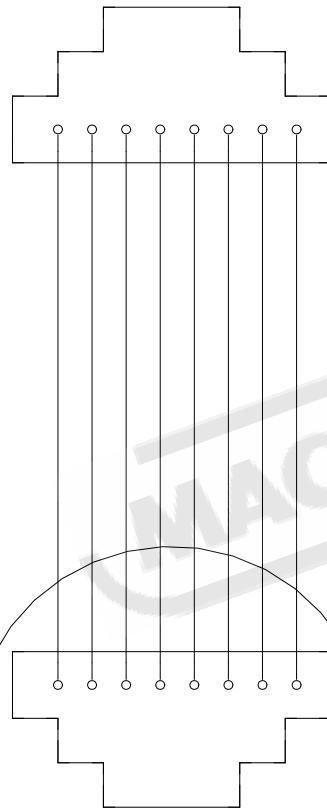

ON THE CABINET
FOR INTERNET

OPERATOR PANEL
RJ45 PORT
LAN2



PLUG HOUSING
19410100522
A

PLUG IN HOUSING
19410100301
A

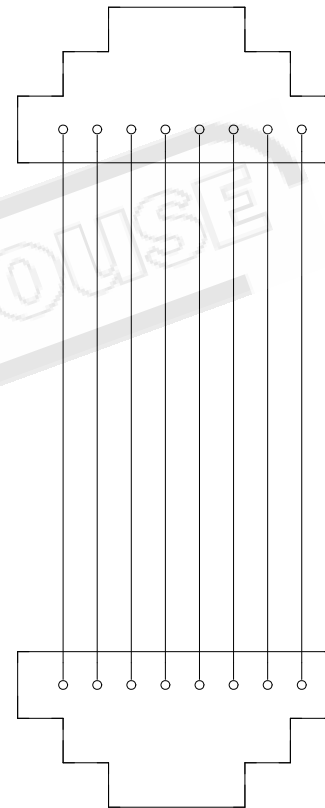

PLC (CPU 1214C)
X1 P1
PROFINET (LAN)

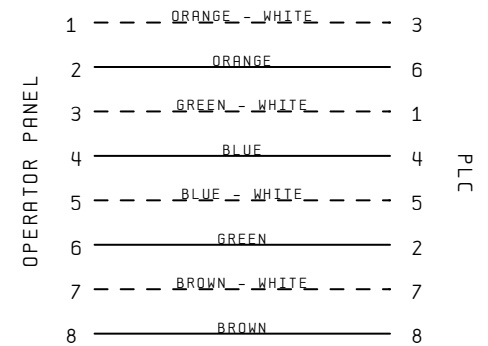
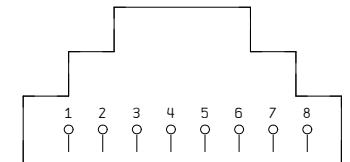

Date	30. Nov. 2022
Drawn by	HUSEYIN KARADUMAN
Checked by	FIRAT CILINGIR
Norm	

HPK 100 NC	Original
------------	----------



COMMUNICATION CONNECTIONS

Drawing number: 28022018	=
File number: HPK1159	+
Project name: HPK1159	
P. 11	
16 P.	

J1

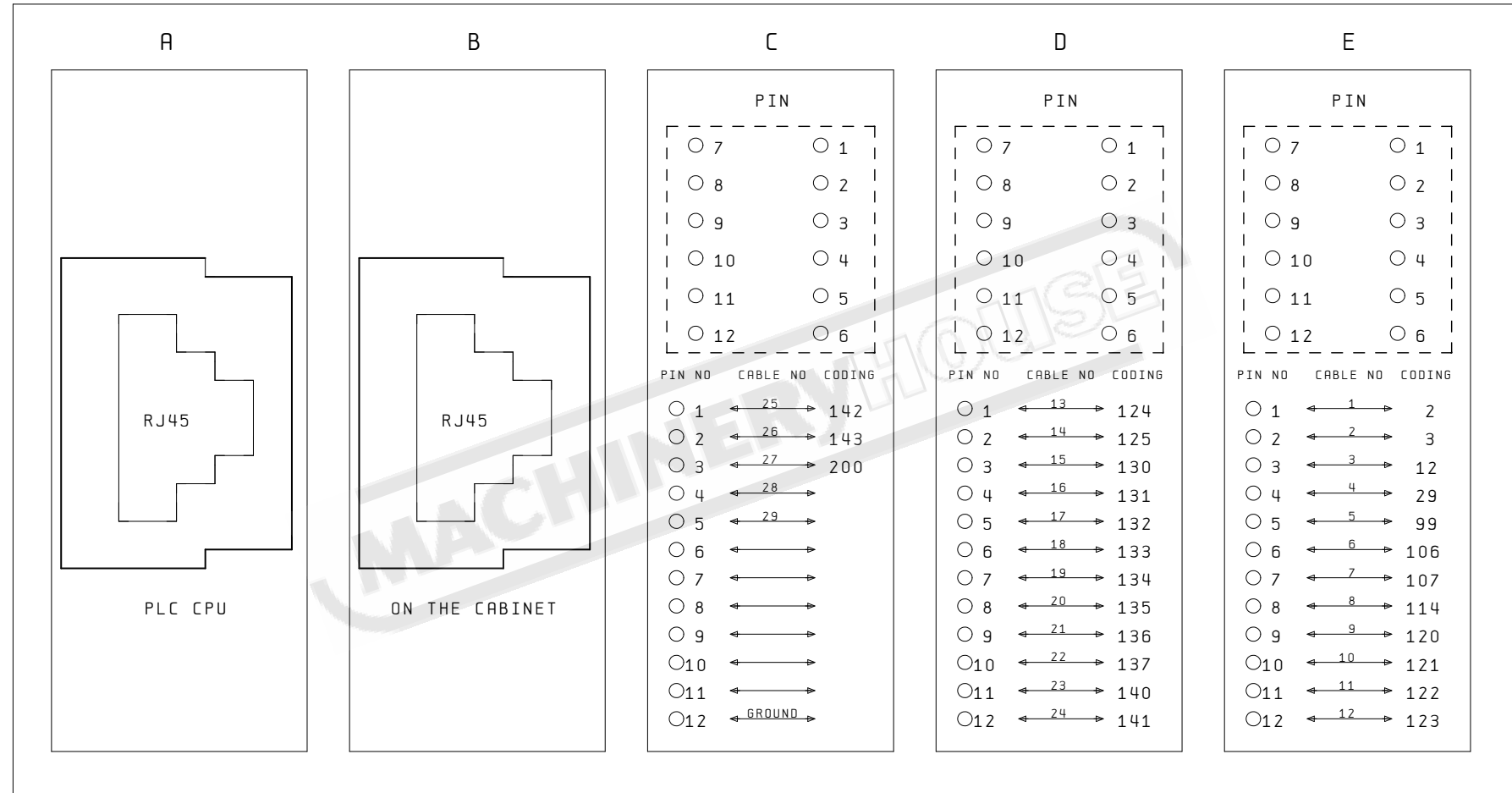

ELECTRICAL PARTS LIST - 1

CODE	EXPLANATION	ORDER NUMBER	MANUFACTURER
Q1	MAIN SWITCH	KG41B T203/09VE	KRAUS - NAIMER
Q2	MOTOR PROTECTION OVERLOAD THERMAL RELAY (14 - 20A)	(3RV2021-4BA10) + (3RV2901-1E)	SIEMENS
K1	MOTOR CONTACTOR	(3RT2026-1BB40) + (3RT2926-1JJ00)	SIEMENS
FSR	PHASE SEQUENCE RELAY	3UG4512 - 1AR20	SIEMENS
G1	POWER SUPPLY INPUT 400-500V 3AC // OUTPUT 24V DC 20A	S8VK-T48024	OMRON
F1	POWER SUPPLY INPUT FUSE	5SQ23 - C2	SIEMENS
F2	PLC DC FEED FUSE	5SQ21 - C2	SIEMENS
F3	PLC INPUTS 24V DC FEED FUSE	5SQ21 - C2	SIEMENS
F4	PLC OUTPUTS 24V DC FEED FUSE	5SQ21 - C6	SIEMENS
F5	OPERATOR PANEL and ENCODERS FUSE	5SQ21 - C3	SIEMENS
F6	PROPORTIONAL VALVE FUSE	5SQ21 - C2	SIEMENS
A1	PLC CPU UNIT	6ES7 214 - 1HG40 - 0XB0	SIEMENS
A2	PLC DIGITAL INPUT EXPANSION MODULE - 1	6ES7 221 - 1BF32 - 0XB0	SIEMENS
A3	PLC DIGITAL INPUT / OUTPUT EXPANSION MODULE - 2	6ES7 223 - 1PL32 - 0XB0	SIEMENS
	ST6 (4 Pcs.)	3031487	PHOENIX CONTACT
	ST6PE (1 Pcs.)	3031500	PHOENIX CONTACT
	ST4 (3 Pcs.)	3031364	PHOENIX CONTACT
	ST4PE (1 Pcs.)	3031380	PHOENIX CONTACT
	ST2,5 (31 Pcs.)	3031212	PHOENIX CONTACT
	ST2,5 PE (1 Pcs.)	3031238	PHOENIX CONTACT
	STTB2,5 DIO/U-0 (21 Pcs.)	3031563	PHOENIX CONTACT
	STTB2,5 (3 Pcs.)	3031270	PHOENIX CONTACT
	PLUG IN HOUSING	19410160301	HARTING
	CRIMP FEMALE (3 Pcs.)	09140122732	HARTING
	RJ45 FEMALE (2 Pcs.)	09140014721	HARTING
	ETHERNET SOCKET	BRJ45	EMAS
	CABINET	301 190 120 000 NC HPK 100_120	

12

14

Date	30. Nov. 2022	HPK 100 NC	 Sahindan METAL MAKINA ENDUSTRI A. S.	ELECTRICAL PARTS LIST - 1 (INSIDE THE CABINET)		Drawing number: 28022018		=	
Drawn by	HUSEYIN KARADUMAN								+
Checked by	FIRAT CILINGIR					File number:	Project name:		
Norm				Original		HPK1159	HPK1159		
								P. 13	
								16 P.	

ELECTRICAL PARTS LIST - 2

CODE	EXPLANATION	ORDER NUMBER	MANUFACTURER
S0	EMERGENCY STOP	XB4 - BS8442	SCHNEIDER ELECTRIC
S1	0-1 POWER SWITCH	XB4 - BG21	SCHNEIDER ELECTRIC
S2 - H2	START BUTTON AND LAMP	XB4 - BW33B5	SCHNEIDER ELECTRIC
S3	PUMP MOTOR STOP BUTTON	XB4 - BA42	SCHNEIDER ELECTRIC
S4 - S5	CONTROL BUTTONS FOR LEFT ROLL MOVEMENT UP & DOWN	ZB4 BA7120 - ZB4 BZ103	SCHNEIDER ELECTRIC
S6 - S7	CONTROL BUTTONS FOR RIGHT ROLL MOVEMENT UP & DOWN	ZB4 BA7120 - ZB4 BZ103	SCHNEIDER ELECTRIC
PL1 - PL2	CONTROL BUTTON FOR ROTATION	UP09	DISPA
S10 - S11	CONTROL BUTTONS FOR LEFT SUPPORT MOVEMENT UP & DOWN	ZB4 BA7120 - ZB4 BZ103	SCHNEIDER ELECTRIC
S12	CONTROL BUTTON FOR LEFT SUPPORT MOVEMENT FORWARD & BACWARD	XB4 - BJ53	SCHNEIDER ELECTRIC
S13	CONTROL BUTTON FOR LEFT SUPPORT MOVEMENT LEFT & RIGHT ROTATION	XB4 - BJ53	SCHNEIDER ELECTRIC
S14 - S15	CONTROL BUTTONS FOR RIGHT SUPPORT MOVEMENT UP & DOWN	ZB4 BA7120 - ZB4 BZ103	SCHNEIDER ELECTRIC
S16	CONTROL BUTTON FOR RIGHT SUPPORT MOVEMENT FORWARD & BACWARD	XB4 - BJ53	SCHNEIDER ELECTRIC
S17	CONTROL BUTTON FOR RIGHT SUPPORT MOVEMENT LEFT & RIGHT ROTATION	XB4 - BJ53	SCHNEIDER ELECTRIC
S18	CONTROL BUTTON ENCODER PNEUMATIC	XB4 - BD21	SCHNEIDER ELECTRIC
	PLUG HOUSING	19410160523	HARTING
	CRIMP MALE (3 Pcs.)	09140122632	HARTING
	RJ45 MALE (2 Pcs.)	09140014622	HARTING
	USB	BUSB	EMAS
OP	OPERATOR PANEL	CMT3072	EASYVIEW

ELECTRICAL CABINET SCHEME

ELECTRIC PANO : 550*850*210mm

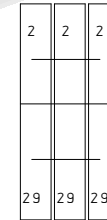
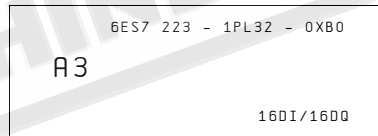
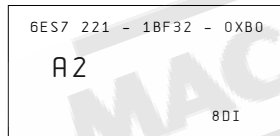
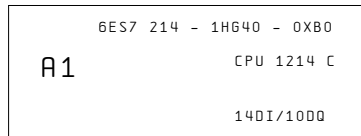

STTB2, 5

L1	L2	L3	N	PE	U	V	W	PE	2	2	3	3	12	29	99	106	107	114	115	120	121	122	123	124	125	130	131	132	133	134	135	136	137	140	141	142	143	200	202	203	204	205	206	207	210	211	230	231	232	233	234	235	236	237	240	241	242	243	244	PE
----	----	----	---	----	---	---	---	----	---	---	---	---	----	----	----	-----	-----	-----	-----	-----	-----	-----	-----	-----	-----	-----	-----	-----	-----	-----	-----	-----	-----	-----	-----	-----	-----	-----	-----	-----	-----	-----	-----	-----	-----	-----	-----	-----	-----	-----	-----	-----	-----	-----	-----	-----	-----	-----	-----	----

ST6

ST4

ST2, 5

STTB2, 5 DIO/U-0

Date	30. Nov. 2022	HPK 100 NC
Drawn by	HUSEYIN KARADUMAN	
Checked by	FIRAT CILINGIR	
Norm		Original



Sahinler
METAL MAKINA
ENDUSTRI A. S.

ELECTRICAL CABINET SCHEME

Drawing number: 28022018

File number:
HPK1159

Project name:
HPK1159